

CODICE	DESCRIZIONE	MATERIALE	QUANTITÀ
55006070	INCONTRO PER FORO Ø6 K-PUSH TECH	FE	3.500

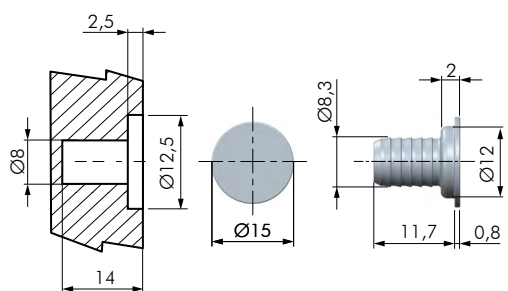

CODICE	DESCRIZIONE	MATERIALE	QUANTITÀ
55006050	INCONTRO PER FORO Ø8 K-PUSH TECH	FE	2.400

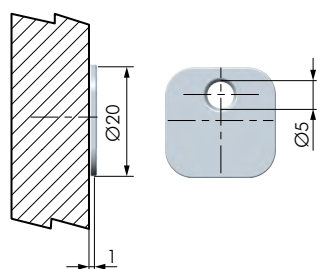

CODICE	DESCRIZIONE	MATERIALE	QUANTITÀ
55006120	INCONTRO QUADRATO CON FORO VITE K-PUSH TECH	FE	5.000

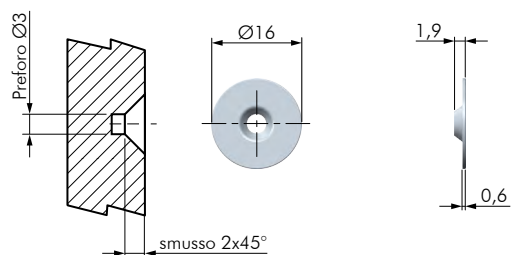

CODICE	DESCRIZIONE	MATERIALE	QUANTITÀ
55006130	INCONTRO ROTONDO CON FORO VITE K-PUSH TECH	FE	15.000

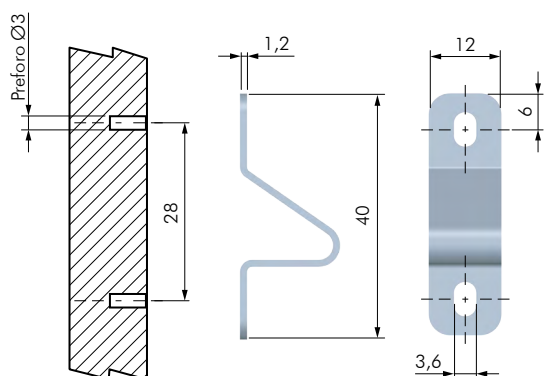
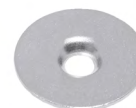

CODICE	DESCRIZIONE	MATERIALE	QUANTITÀ
55006110	BASETTA PER TERMINALI CURVI K-PUSH TECH	FE	2.500

