



# WEEN

## KIT CERNIERE ANTA AFFIANCATA 160KG



Kit Cerniere e braccio Ween per anta affiancata | Passive sash Ween hinge and arm | Charnières et bras pour dormant | Bisagras y compás para hoja pasiva



Cerniere in estruso e zama, contropiastre e viti; braccio con leva, viti e grani in acciaio inox, corpo in zama.



Extruded aluminum and zamak hinges, counterplates and screws; arm lever, screws and setscrews in stainless steel, zamak body.



Charnières en aluminium extrudé et zamak, gâches et vis; bras levier, vis et grains en acier inox, corps en zamak.



Bisagras de aluminio extruido y zamac, cerraderos y tornillos; Compás con leva tornillos y prisioneros de acero inox, cuerpo de zamac.



ART.	3420.23			
Imballo   Package   Conditionnement   Embalaje	5 Pz			
Finiture disponibili   Available finishes Finitions disponibles   Acabados disponibles	1	2	3	4

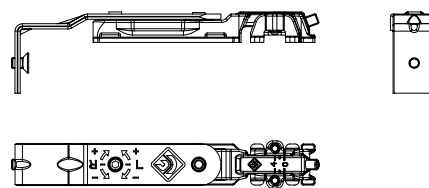
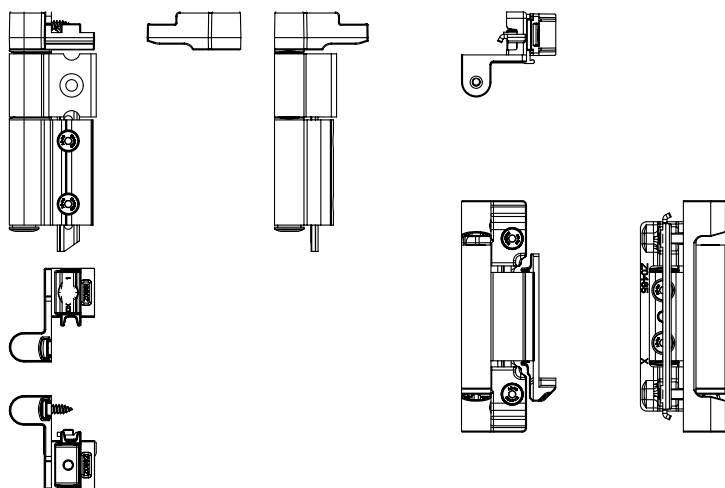

### REGOLAZIONI | ADJUSTEMENT

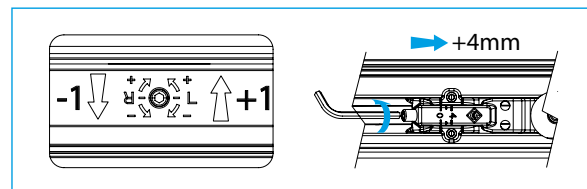

### REGOLAZIONI | ADJUSTEMENT

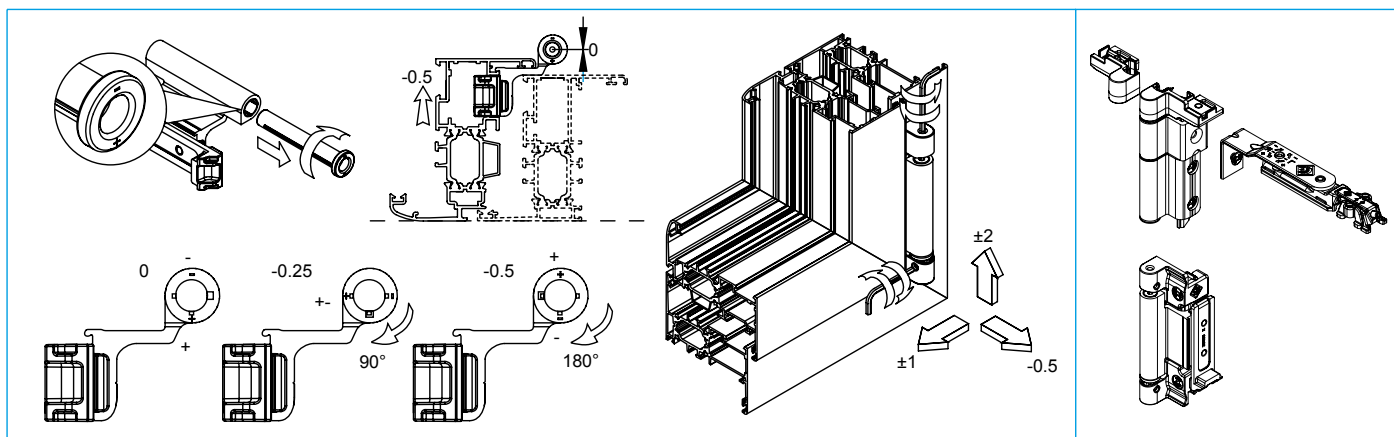

ART.	NODO SECTION
3420.23	A01 - A02 - A03 - A04 - A05 - A06 - A07

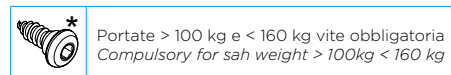
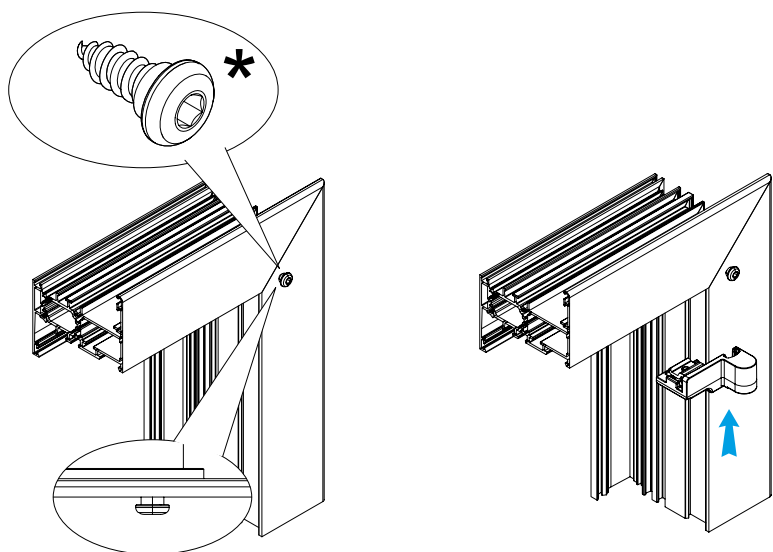

TABELLA DI CARICO | LOAD CHART

PESO MASSIMO DELL'ANTA (alluminio + vetro = 160 Kg) MAXIMUM WEIGHT OF THE SASH (aluminium + glass = 160 Kg)										
Spessore max. del vetro indicato (es. 30 mm) Maximum thickness of the glass (es. 30 mm)						N.D. = Dimensione Non Disponibile N.D. = Dimension Not Available				
Nota: Lo spessore massimo del vetro impiegabile si riferisce al materiale senza la camera d'aria Note: The maximum thickness of the glass is considered without the air-space										
2700	50	50	47	40	34	30	26	24	22	20
2600	50	50	49	41	35	31	27	25	22	21
2500	50	50	50	43	37	32	28	26	23	21
2400	50	50	50	44	38	33	30	27	24	22
2300	50	50	50	46	40	35	31	28	25	23
2200	50	50	50	48	42	36	32	29	26	24
2100	50	50	50	50	44	38	34	30	28	25
2000	50	50	50	50	46	40	36	32	29	27
1900	50	50	50	50	48	42	37	34	31	28
1800	50	50	50	50	50	44	40	36	32	30
1700	50	50	50	50	50	47	42	38	34	31
1600	50	50	50	50	50	50	44	40	36	33
1500	50	50	50	50	50	50	47	43	39	36
1400	50	50	50	50	50	50	50	46	42	34
1300	50	50	50	50	50	50	50	49	40	37
1200	50	50	50	50	50	50	50	48	44	40
1100	50	50	50	50	50	50	50	50	48	36
1000	50	50	50	50	50	50	50	50	44	32
900	50	50	50	50	50	50	50	43	39	24
800	50	50	50	50	50	50	50	48	29	13
700	50	50	50	50	50	50	50	18	x	x
600	50	50	50	50	50	50	24	x	x	x
500	50	50	50	50	50	x	x	x	x	x
H \ L	370	400	500	600	700	800	900	1000	1100	1200