

211696 - Forbice ad angolo premontata MM senza aerazione controllata 800 LBB 601-800 argento

Disegni tecnici

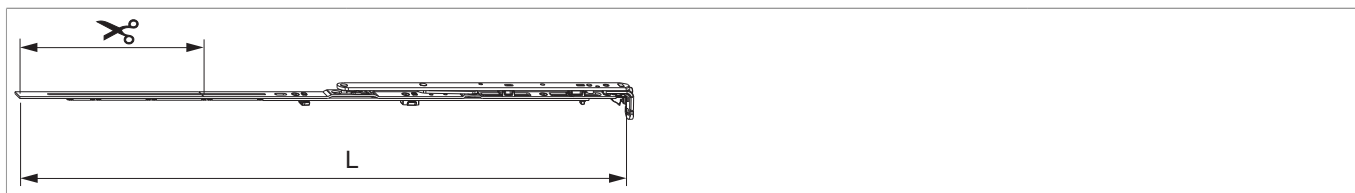

						L		Nº
argento	Forbice ad angolo premontata MM	800	601 - 800	491 - 690	210	696,5	20	211696

Tabella posizionamento viti

Nº		1	2	3	4	5	6	
211696	4	18,5	91,5	250	377			

Tabella punti di chiusura

Nº		Z1	
211696	0		

Schema di tranciatura

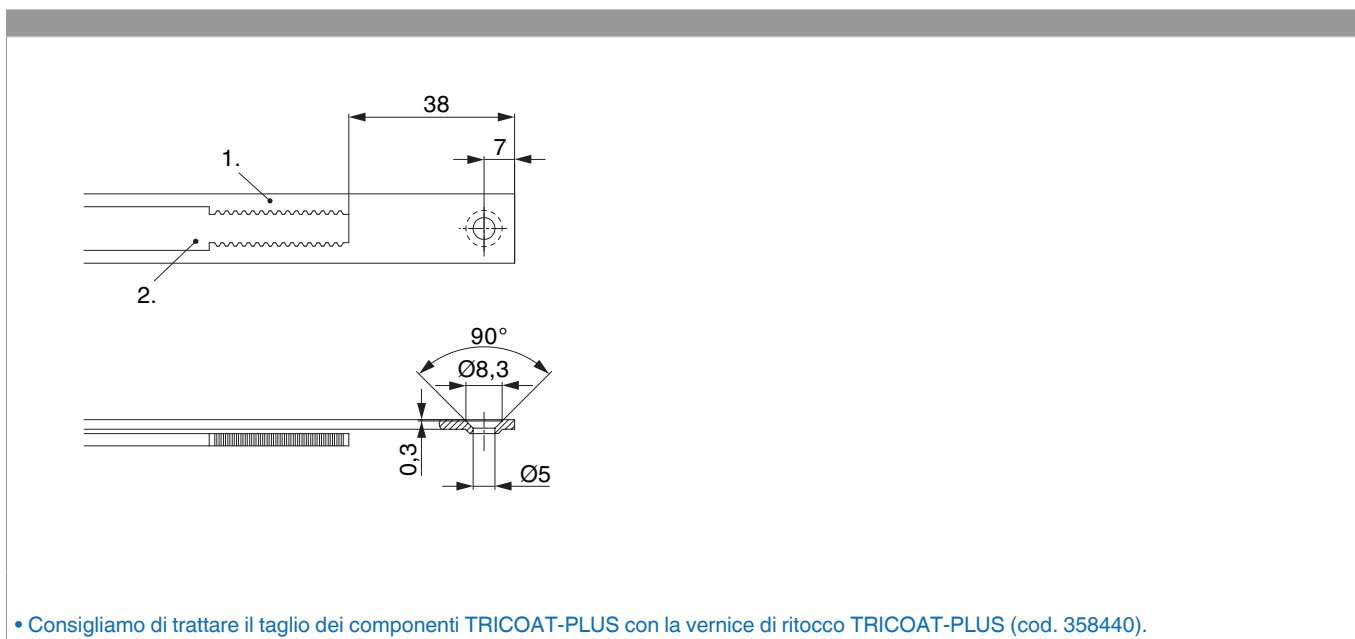

• Consigliamo di trattare il taglio dei componenti TRICOAT-PLUS con la vernice di ritocco TRICOAT-PLUS (cod. 358440).

- 1. Frontale
- 2. Asta mobile

Collegamento a clips

Agganciare collegamenta a clips

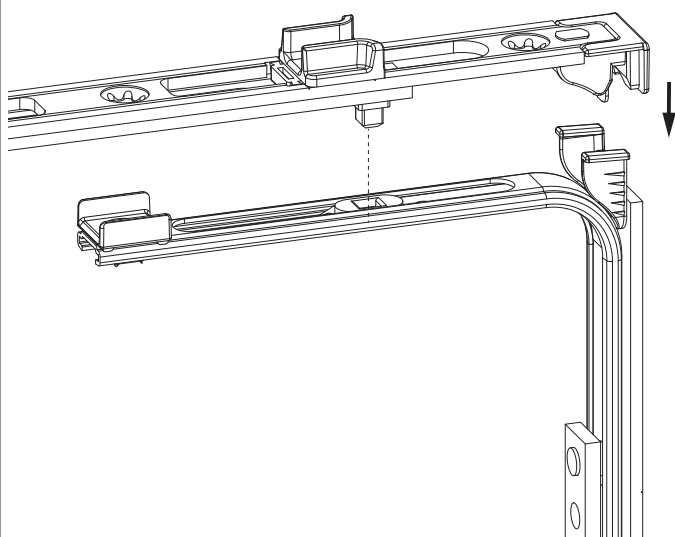

Sganciare collegamento clips

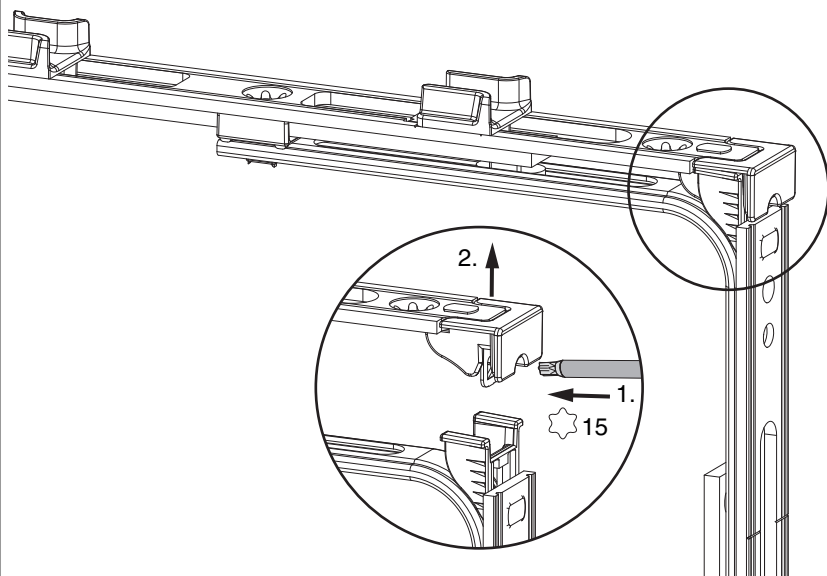

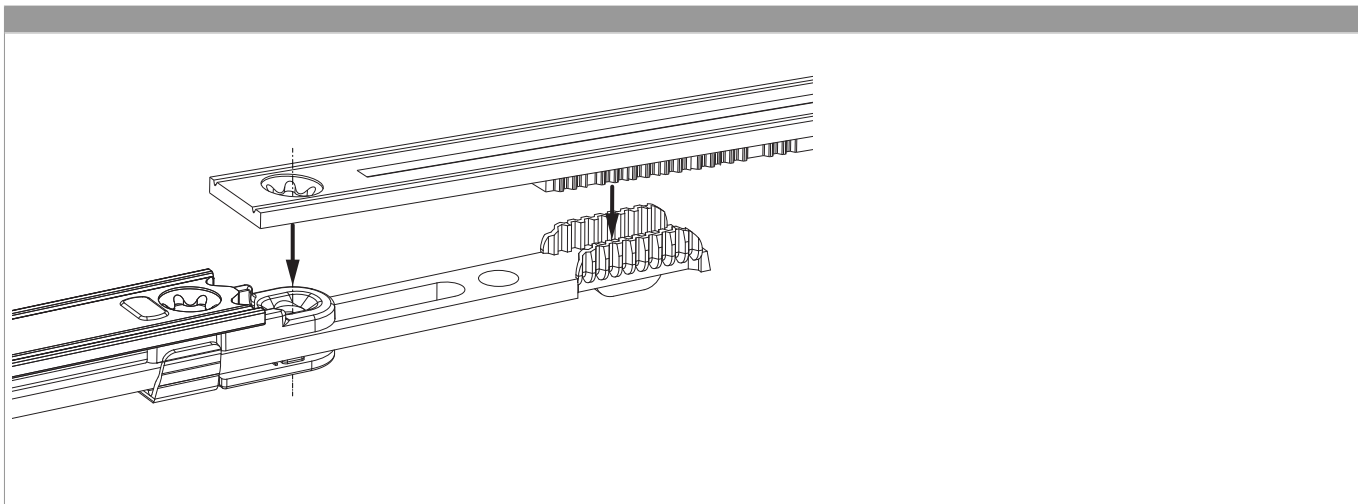

Collegamento scarpetta dentata

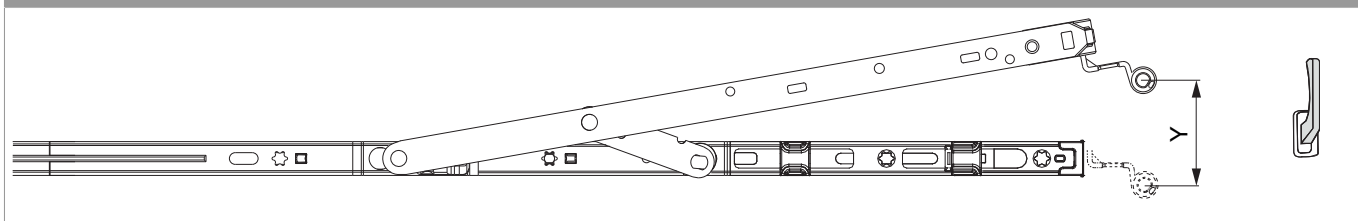

Raggio di apertura

Posizione a ribalta



	Y
400	120
600	125
800	125
1050	127
1300	127

Regolazione laterale

nel braccio forbice

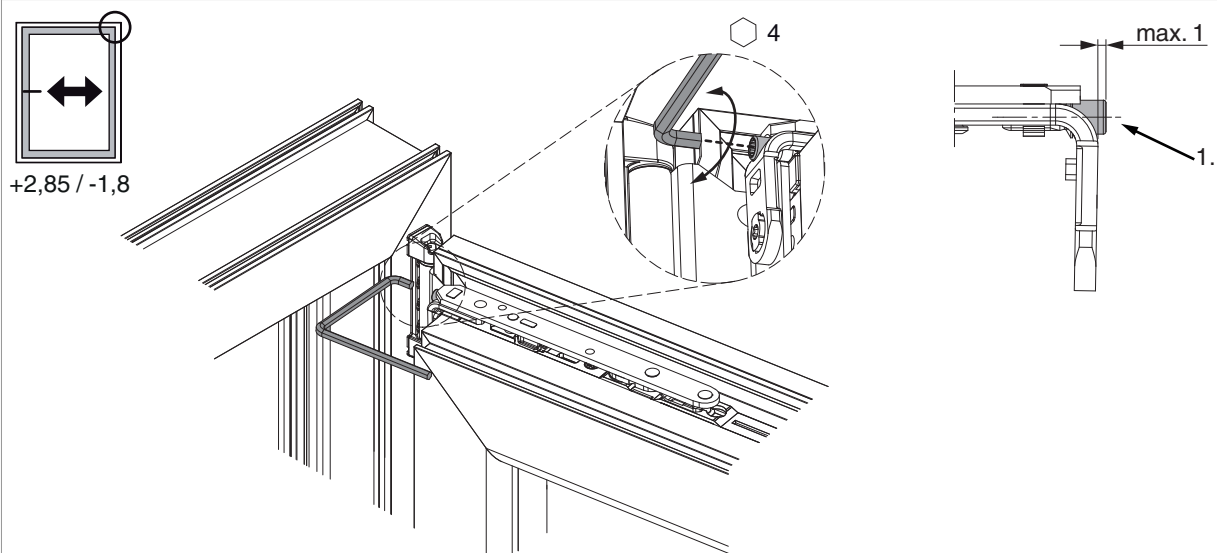

1. Durante l'abbassamento dell'anta assicurarsi che la vite non fuoriesca completamente. La testa della vite deve sporgere al massimo 1 mm!

Regolazione pressione

nel braccio forbice

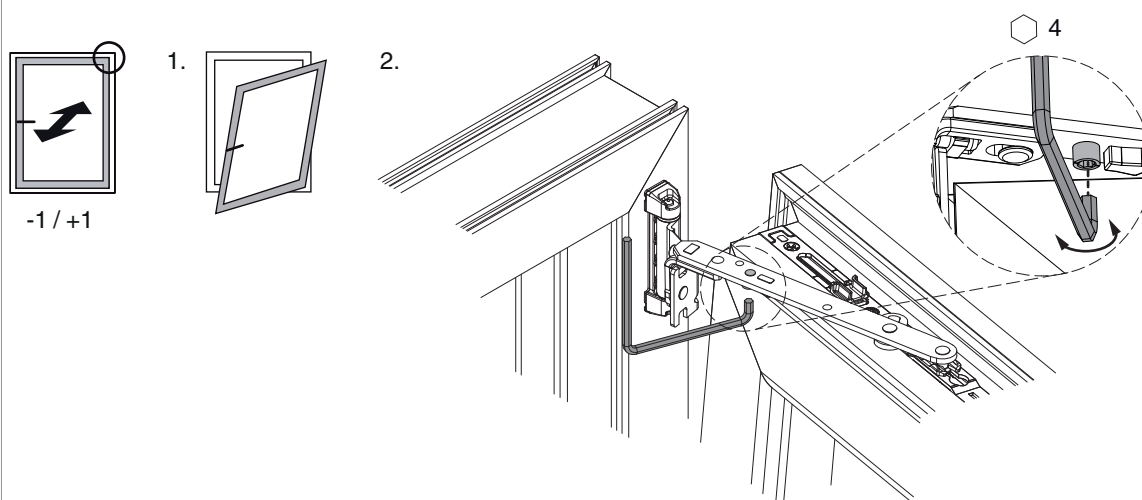

Fungo e nottolino

