

The Drawing and its contents are to be kept secret from third parties, particularly competitors. The drawing and documents which go with it are not to be duplicated either in local or extract, or used in other documentation without express approval (§15 and §18 UrHG - §1 and §18 UWG). A reservation of rights in accordance with §12 PatG is declared for the event that a patent is granted.

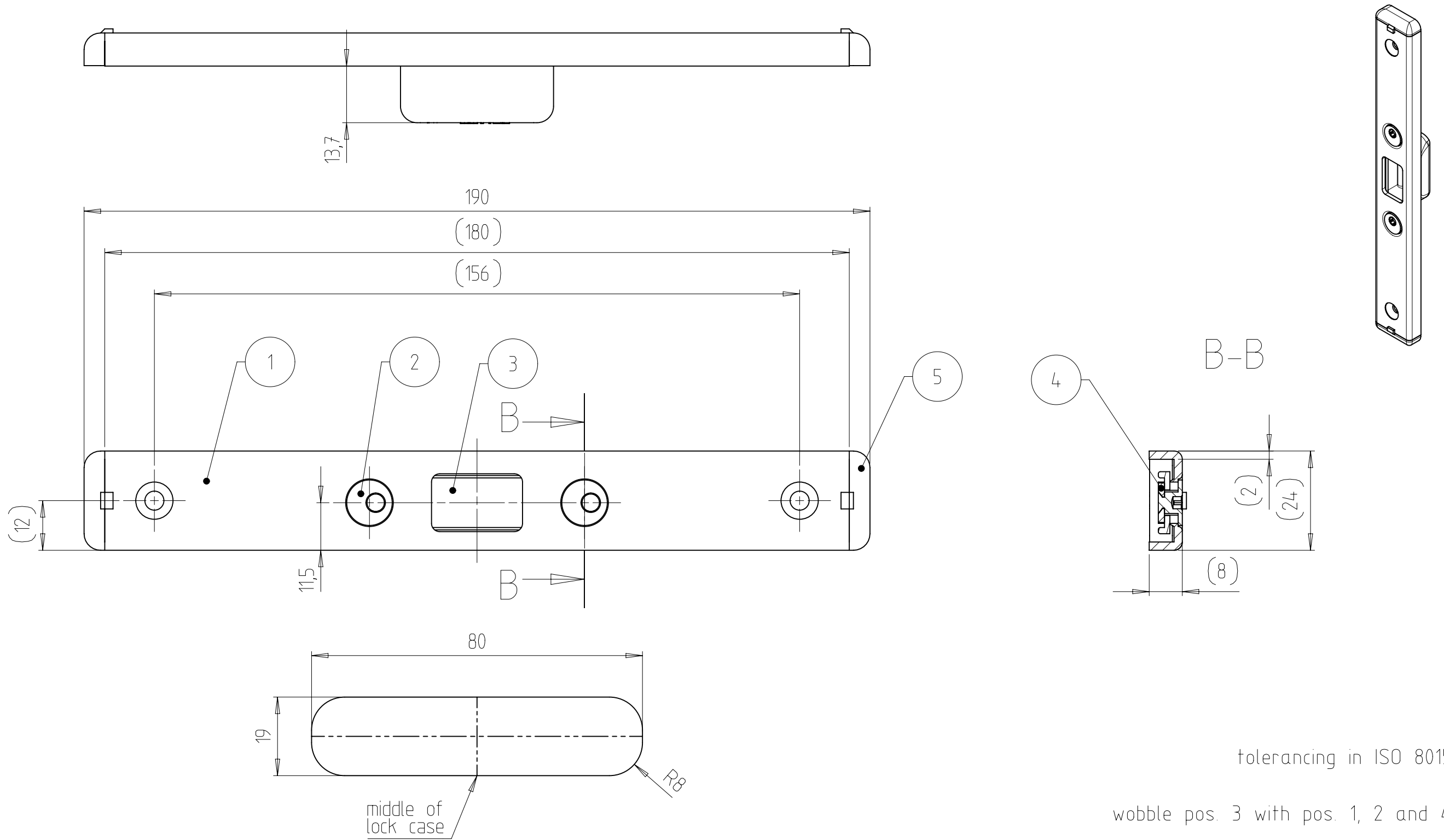

tolerancing in ISO 8015

wobble pos. 3 with pos. 1, 2 and 4

insert pos. 5 into Pos. 1

milling-depth = specified depth + min. 1 mm

milling tool \varnothing 16 mm
stop ring \varnothing 27 mm

POS	DESCRIPTION	QTY	PART NUMBER	PART	COMMENT
5	end cap	2	9.811.00051	000	
4	washers	1	9.738.00019	000	
3	eccentric step spike	2	9.714.00050	000	
2	lock case	1	9.881.00075	000	
1	u-profile striker plate	1	9.865.00061	000	

Qty. 1	Type of Modification Zeichnungblatt 2 hinzugefügt auf Englisch	ANT EK1-22114.01	Drawn M. M.-Bachem	Approved P. Thode	Date 14.03.2022
Volume /mm ³ 19332	Weight/g 103,986	Material-No.	Item-No. USB 2325-08-246	Tool-No.	
		Tolerance ISO 2768 mK	Part-Description U-Profil Schliessblech u-profile striker plate		
Scale 1 : 1		Additional Notice		Document No. 7.865.00536	Doc. Part No. 000
Drawn Symne	KFV	Revision 26		Status 20	
Date 10.05.1995		Replacement for :		Test procedure	
Appr. Buerger		Replaced by :		Size A3	
Date 11.05.1995					