







<p>IT COMANDI ESTERNI PER MANIGLIONI ANTIPANICO</p> <p>Foglio istruzioni per installatore</p> <p>AVVERTENZE Le caratteristiche di questo prodotto rivestono la massima importanza per la sicurezza delle persone e non è consentito apportare al prodotto modifiche diverse da quelle descritte in queste istruzioni.</p> <p>Valori limite prescritti dalla UNI EN 1125 con maggiorazione. Il prodotto è idoneo per l'utilizzo su porte standard e/o tagliafuoco.</p>	<p>EN OUTSIDE ACCESS DEVICES FOR PANIC EXIT DEVICES</p> <p>Instruction sheet for locksmiths</p> <p>WARNING These product characteristics are essential to ensure personal safety. No changes may be made to the product other than those described in this instruction sheet.</p> <p>Limit values prescribed by UNI EN 1125 with extension. This product is certified for use on standard and/or fire doors.</p>	<p>FR ENSEMBLES DE MANŒUVRE EXTÉRIEURS POUR FERMETURES ANTIPANIQUE</p> <p>Notice d'instructions pour l'installateur</p> <p>AVERTISSEMENTS Les caractéristiques de ce produit sont extrêmement importantes pour la sécurité des personnes : il est donc interdit d'apporter au produit toute modification différente de celles qui sont décrites dans ces instructions.</p> <p>Valuers limite prescrites par la norme UNI EN 1125 avec majoration. Le produit peut être utilisé sur des portes standard ou coupe-feu.</p>	<p>E MANDOS EXTERNOS PARA BARRAS ANTIPANICO</p> <p>Hoja de instrucciones para el instalador</p> <p>ADVERTENCIAS Las características de este producto tienen la máxima importancia para la seguridad de las personas. No está permitido realizar modificaciones diferentes a las descritas en estas instrucciones.</p> <p>Valores límite prescritos por la norma UNI EN 1125 con incremento. El producto es idóneo para el uso en puertas estándar y/o cortafuegos.</p>
---	--	--	--



<p>SIMBOLOGIA</p>  <p>Art. 1-07078-36/38-0</p>	<p>SYMBOLS</p>  <p>Art. 1-07078-68-0</p>	<p>SYMBOLES</p>  <p>Art. 1-07078-69-0</p>
--	--	---

<p>Porta di mano destra (R). Porta di mano sinistra (L). Funzione opzionale (OPT). N.º articolo maniglione antipanico.</p>	<p>Right-handed door (R). Left-handed door (L). Optional function (OPT). Panic exit device item no.</p>	<p>Porte avec sens d'ouverture à droite (R). Portes avec sens d'ouverture à gauche (L). Fonction optionnelle (OPT). N.º article fermeture antipanique</p>	<p>Puerta de mano derecha (R). Puerta de mano izquierda (L). Función opcional (OPT). N.º artículo barra antipánico.</p>
--	---	---	---

				
---	---	---	---	---

<p>Controllare planarità Check flatness Contrôler la planéité Control planeidad</p> 	<p>Appoggiare Place Poser Apoyar</p> 	<p>Allineare Align Aligner Alinear</p> 	<p>Utilizzo dima Use template Utilisation du gabarit Uso plantilla</p> 	<p>Verdere testi note See notes Voir les textes des notes Ver notas</p> 	<p>Verdere istruzioni See instructions Voir les instructions Ver instrucciones</p> 
--	--	--	--	---	--

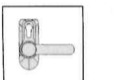
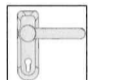







Abbinamento con maniglione	Installation with panic exit device	Installation avec fermeture antipanique	Combinación con barra
----------------------------	-------------------------------------	---	-----------------------

			
59800 - 59801	■	■	■
59810 - 59811	■	■	■
59815 - 59816	■	■	■
59000 - 59001	■	■	■
59010 - 59011	■	■	■
59015 - 59016	■	■	■
59050 - 59051	■	■	■
59060 - 59061	■	■	■
59065 - 59066	■	■	■
59301	■	■	■
59311	■	■	■
59316	■	■	■
59351	■	■	■
59361	■	■	■
59366	■	■	■

Validità tavole istruzioni	Instruction table validity	Validité schémas d'instructions	Validez láminas instrucciones
----------------------------	----------------------------	---------------------------------	-------------------------------

Numero / Descrizione tavola / Table Number / Description / Numéro / Description schéma / Número / Descripción lámina			
--	---	---	---

T.1	<p>Settaggio mano-Controllo segni Changing hand - Checking marks Réglage du sens d'ouverture - Contrôle des marques Inversión mano - Control marcas</p>	■	■	■
T.2	<p>Trasformazione chiave non estraibile Changing non-removable key Transformation clé non extractible Transformación llave no extraíble</p>	■	■	■
T.3	<p>Taglio perno quadro/linguetta, viti Cutting square spindle/tab, screws Coupe tige carrée/languette, vis Corte perno cuadrado/lingüeta, tornillos</p>	■	■	■
T.4	<p>Foratura Drilling Perçage Perforación</p>	■	■	■
T.5	<p>Fissaggio e verifiche finali Fixing and final checks Fixation et vérifications finales Fijación y controles finales</p>	■	■	■

Rif / Ref / Réf / Ref	Testi note	Notes	Textes des notes	Textos notas	
T.1		Inserire maniglia e fissare a fondo con vite. Inserire boccolla 10 solo su articolo: 07078-36-0	Insert handle and fix tightly with screw. Insert bushing 10 only on item: 07078-36-0.	Assembler la poignée et fixer en serrant la vis à fond. Assembler la douille 10 uniquement sur l'article : 07078-36-0	Inserte la manilla y fije a fondo con el tornillo. Inserte el casquillo 10 solo en el artículo: 07078-36-0
		Ruotare fino ad allineare la tacca B con il riferimento opposto.	Rotate until notch B is aligned with opposite reference mark.	Tourner jusqu'à ce que le repère B soit aligné avec la référence opposée.	Gire hasta alinear la marca B con la referencia opuesta.
		Il prodotto è settato di mano R; per adeguare il senso di rotazione della chiave alla mano L svitare la vite A e sfilare la piastrina B. Ruotarla di 180° e rimontarla dall'altro lato.	The product is set for right-handed doors; to change the direction of the key for left-handed doors, unscrew the screw A and remove the plate B. Rotate it 180° and reinstall on the other side.	Le produit standard est configuré sens droit (R) ; afin d'ajuster le sens de la rotation de la clé en fonction du sens gauche (L) de la porte : Dévisser la vis A et retirer la plaque B. Inversez la en la tournant à 180° et placez-la de l'autre côté.	El producto está configurado con mano derecha (R); para adecuar el sentido de rotación de la llave a la mano izquierda (L), desatornque el tornillo A y extraiga la placa B. Gírela 180° y móntela del otro lado.
T.5		Inserire perno quadro 10 nell'ingegno 4 del maniglione.	Insert square spindle 10 in follower 4 of panic exit device..	Assembler la tige carrée 10 dans le fouillot 4 de la fermeture antipanique.	Introduzca el perno cuadrado 10 en la leva 4 de la barra.
		Posizionare colonnette 8 sui due fori esterni.	Insert rods 8 in the two external holes.	Positionner les colonnettes 8 dans les deux trous extérieurs.	Coloque los pernos prisioneros 8 en los dos orificios externos.
		Verificare movimento libero dei meccanismi interni (eventualmente accorciare lunghezza perno quadro).	Check internal mechanisms can move freely (shorten square spindle if necessary).	Vérifier que le mouvement des mécanismes internes est libre (raccourcir éventuellement la longueur de la tige carrée).	Verifique el libre movimiento de los mecanismos internos (si es necesario, acorte el perno cuadrado).
		Azionando il comando lo scrocco deve rientrare senza forzature e ritornare liberamente al rilascio.	When the control device is operated, the latchbolt must withdraw smoothly and travel back freely when released.	Quand on actionne l'élément de manœuvre, le pêne demi-tour doit rentrer sans forcer et revenir librement quand on le relâche.	Accionando el mando, el picaporte debe retroceder sin forzamientos y volver libremente al soltarlo.
		Per un punzonamento ottimale posizionare la camma a 45° è comunque possibile montare cilindri con camme a 0° o 22°.	For optimal drilling, place the cam at 45°; cylinders with 0° to 22° cam may be used.	Pour un poinçonnement optimal, positionner la came à 45° ; il est toutefois possible de monter des cylindres avec des cammes à 0° ou 22°.	Para obtener un punzonado ideal, coloque la leva a 45°. De todas formas, es posible instalar cilindros con levas a 0° o a 22°.

COMPONENTI	COMPONENTS	COMPOSANTS	COMPONENTES
NOTA: i riferimenti dell'esploso sono riportati sulle figure per riconoscere il componente.	NOTE: references to the exploded view are printed on the figures to help identify each component	NOTE : les références de la vue éclatée sont indiquées sur les figures pour reconnaître le composant	NOTA: Las referencias del dibujo de despiece están indicados en las figuras para reconocer el componente

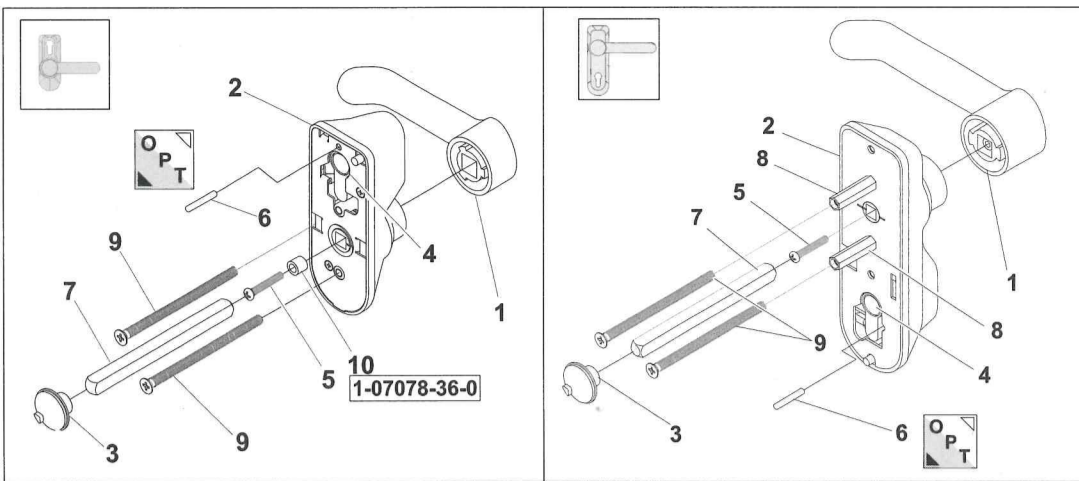

Ref. Q.ty	Componenti/ Components/ Composants / Componentes
1	1 Maniglia / Handle / Poignée / Manilla
2	1 Scatola principale / Main case / Boîtier principal / Cofre principal
3	1 Ingegno comando esterno / Follower outside access device / Fouillot élément de manœuvre extérieur / Leva mando esterno
4	1 Cilindro con chiave / Cylinder with key / Cylindre avec clé / Cilindro con llave
5	1 Vite fissaggio maniglia / Handle fixing screw / Vis de fixation de la poignée / Tornillo de fijación de la manilla
6	1 Perno blocco chiave / Key rotation stop / Axe de blocage de la clé / Perno de bloqueo de la llave
7	1 Quadro 8 mm / Square spindle 8 mm / Carré 8 mm / Perno quadro 8 mm
8	2 Colonna / Rod / Colonne / Perno prisionero
9	2 Vite di fissaggio / Fixing screw / Vis de fixation / Tornillo de fijación
10	1 Boccolla / Bushing / Douille / Casquillo

T.1	INVERSIONE MANO - CONTROLLO SEGNI	CHANGING HAND - CHECKING MARKS	INVERSION DU SENS D'OUVERTURE - CONTRÔLE DES MARQUES	INVERSIÓN MANO - CONTROL MARCAS
------------	-----------------------------------	--------------------------------	--	---------------------------------

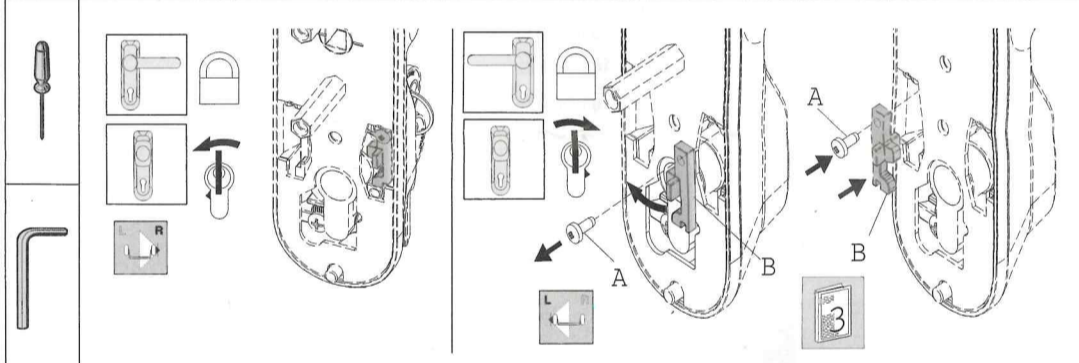
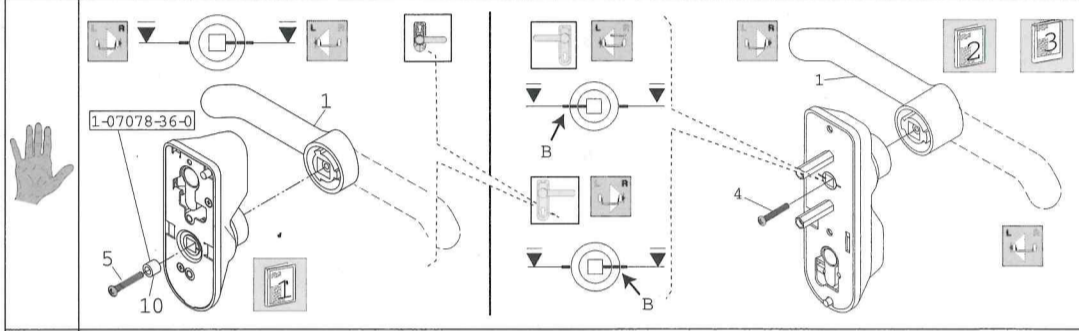

T.2	TRASFORMAZIONE CHIAVE NON ESTRAIBILE	CHANGING NON-REMOVABLE KEY	TRANSFORMATION CLÉ NON EXTRAÏBLE	TRANSFORMACIÓN LLAVE NO EXTRAÍBLE
------------	--------------------------------------	----------------------------	----------------------------------	-----------------------------------

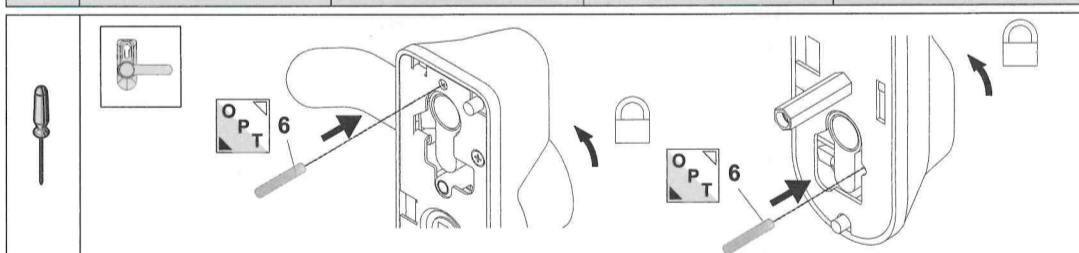

T.3	TAGLIO PERNO QUADRO/LINGUETTA E VITI	CUTTING SQUARE SPINDLE/TAB AND SCREWS	COUPE TIGE CARRÉE/LANGUETTE ET VIS	CORTE PERNO CUADRADO/ LENGÜETA Y TORNILLOS
------------	--------------------------------------	---------------------------------------	------------------------------------	--

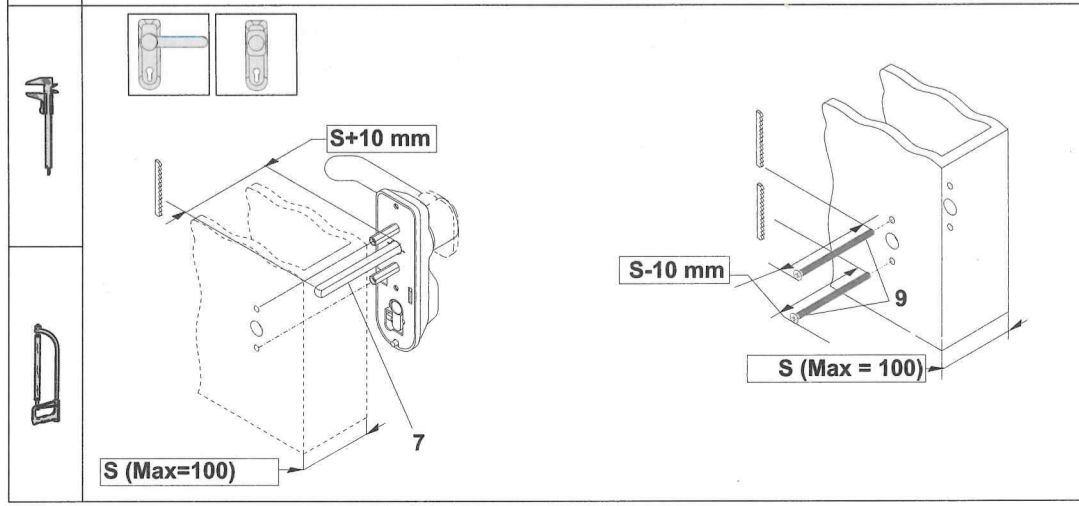
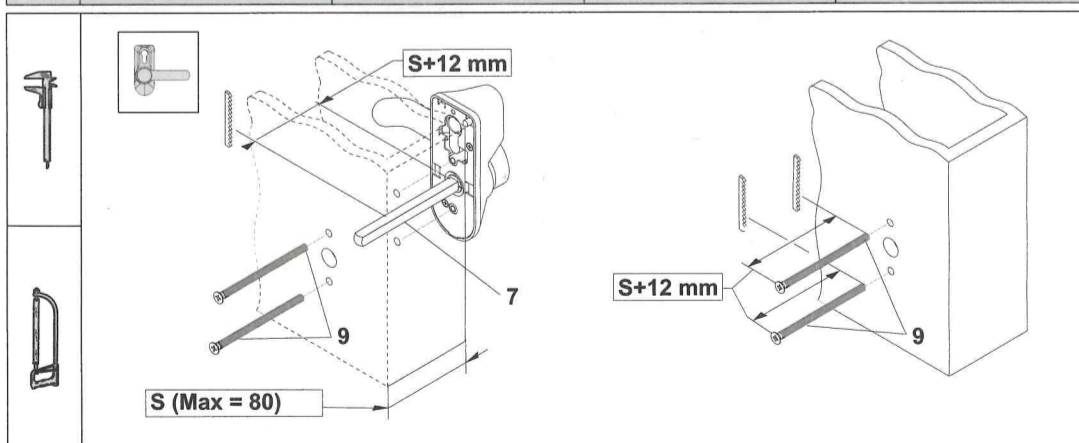

	M= S+12 mm	L= S+12 mm	M= S+12 mm	L= S+12 mm	-	-	Z= 80 mm
	M= S+10 mm	L= S-13 mm	M= S+9 mm	L= S-13 mm	M= S+10 mm	L= S-13 mm	Z= 100 mm
	M= S+10 mm	L= S-13 mm	M= S+10 mm	L= S-13 mm	M= S+10 mm	L= S-13 mm	Z= 100 mm
	59001 - 59051 59011 - 59061 59016 - 59066		59801 59811 59816		59301, 59311, 59316, 59351, 59361, 59366		

T.4 FORATURA DRILLING PERÇAGE PERFORACIÓN

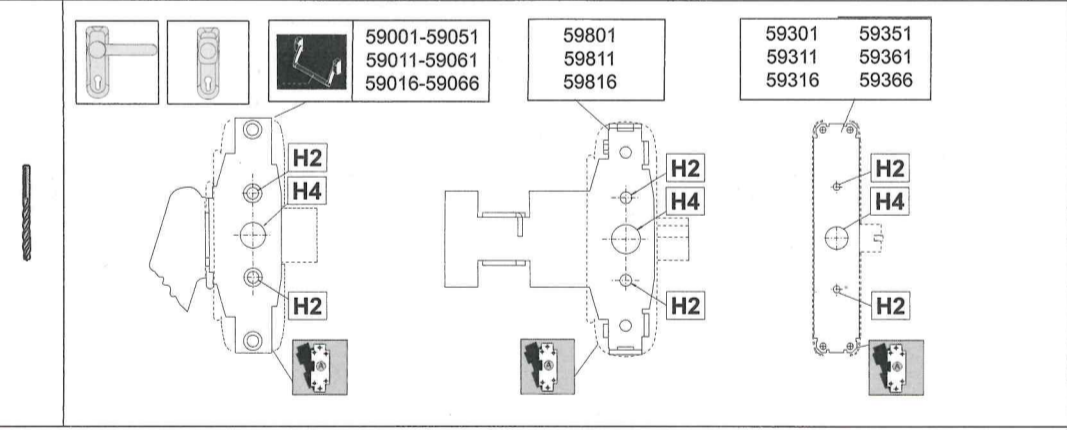
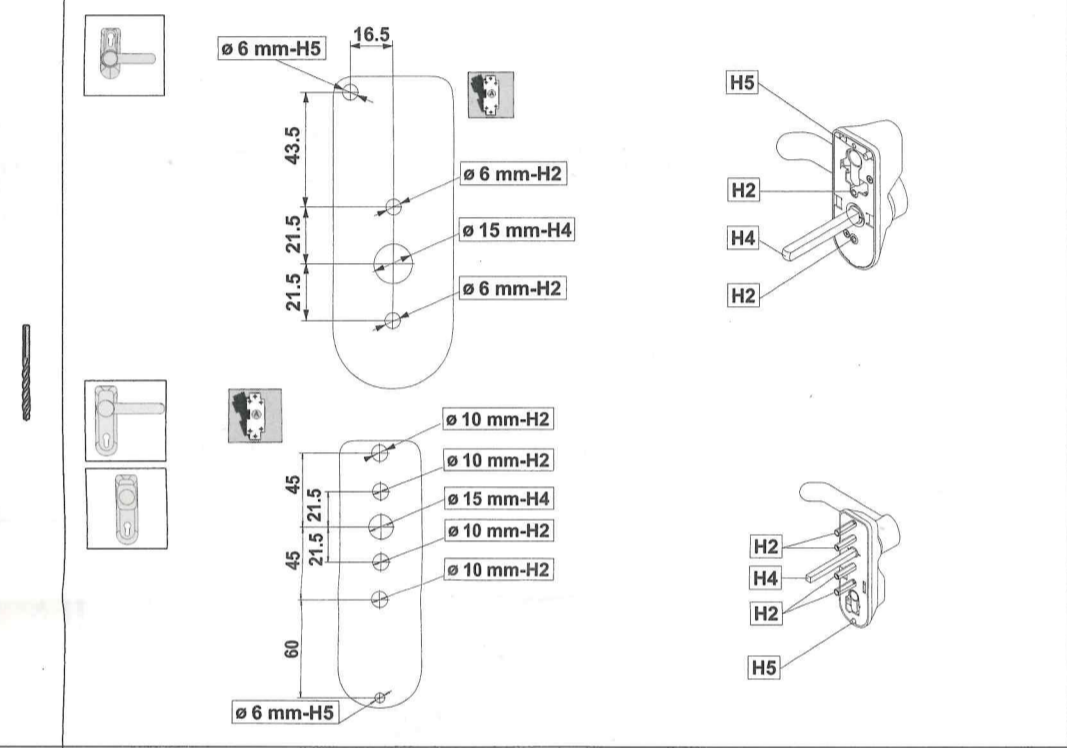

T.5 FISSAGGIO E VERIFICHE FINALI FIXING AND FINAL CHECKS FIXATION ET VÉRIFICATIONS FINALES FIJACIÓN Y CONTROLES FINALES

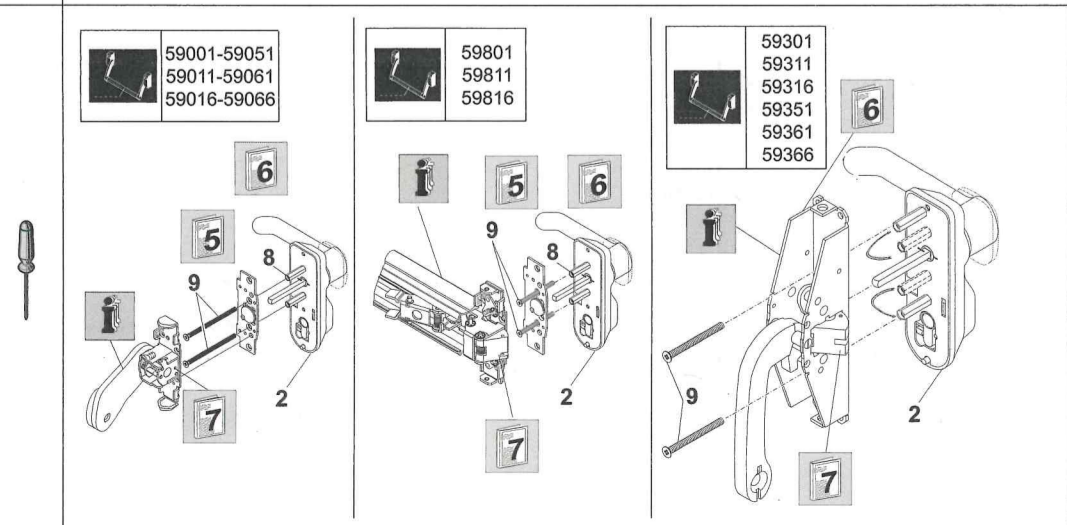
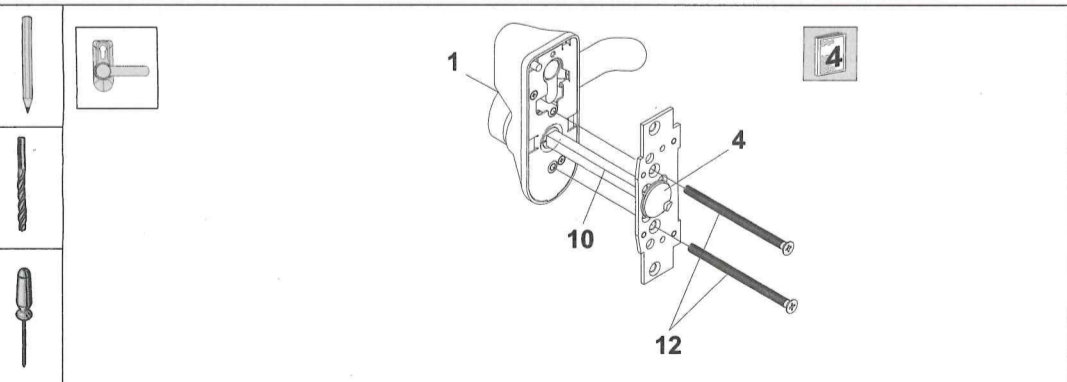

T.6 DIME TEMPLATES GABARITS PLANTILLAS

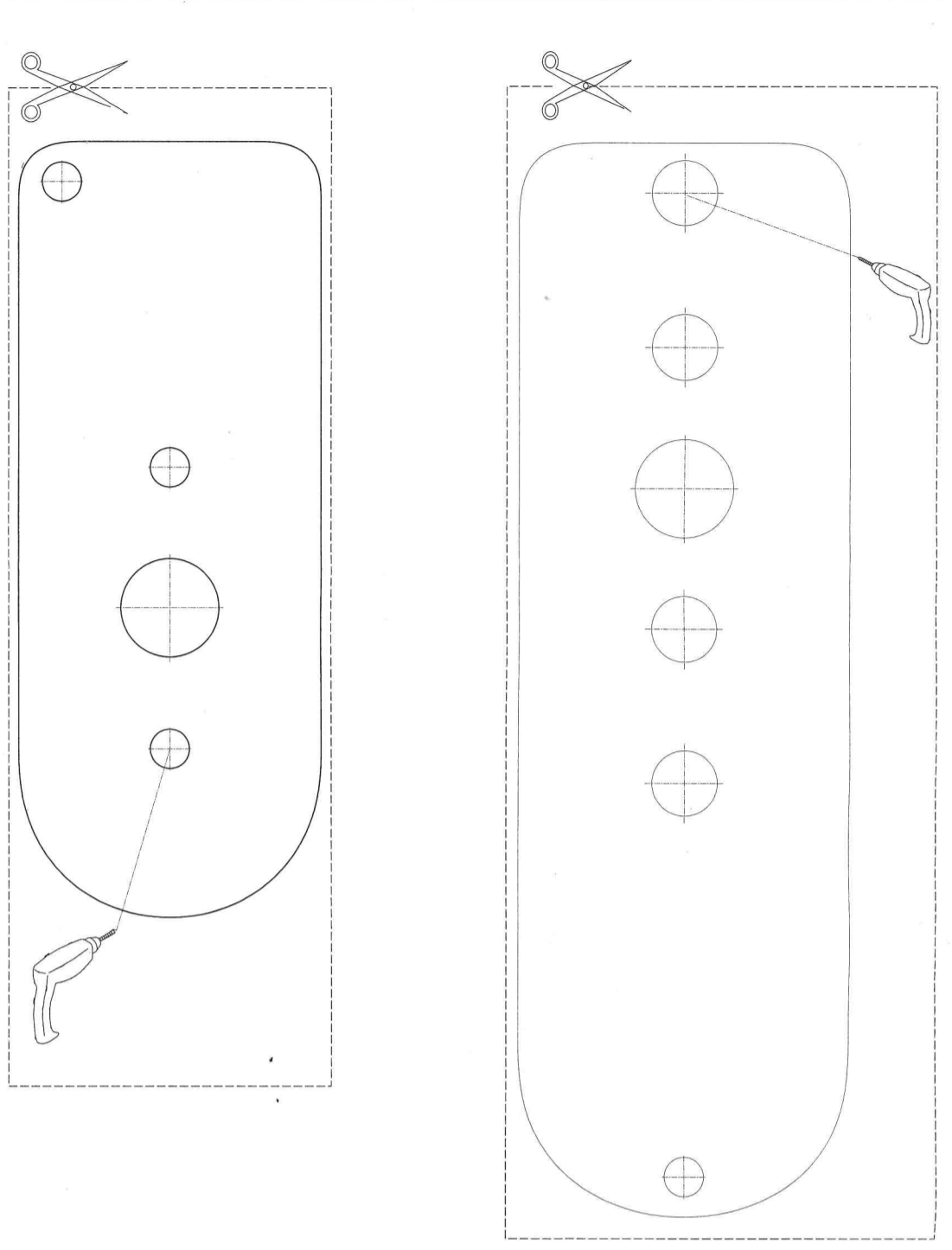

T.7 SOSTITUZIONE CILINDRO REPLACING CYLINDER REMPLACEMENT CYLINDRE SUSTITUCIÓN DEL CILINDRO

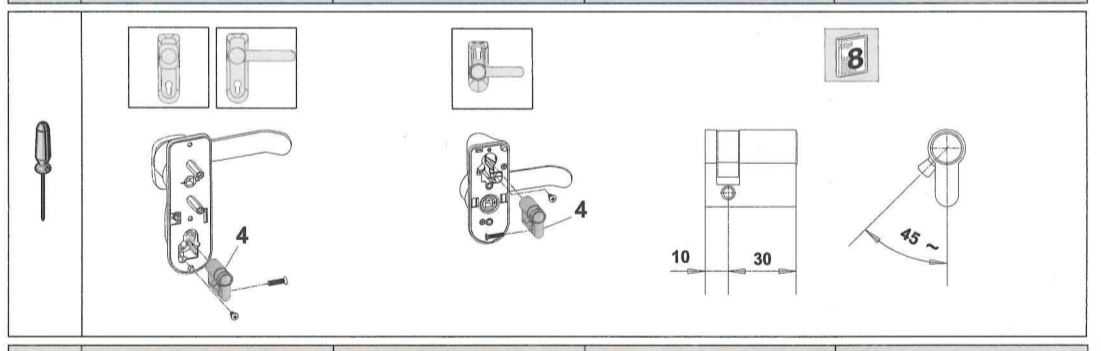

T.8 ACCESSORI ACCESSORIES ACCESSOIRES ACCESORIOS

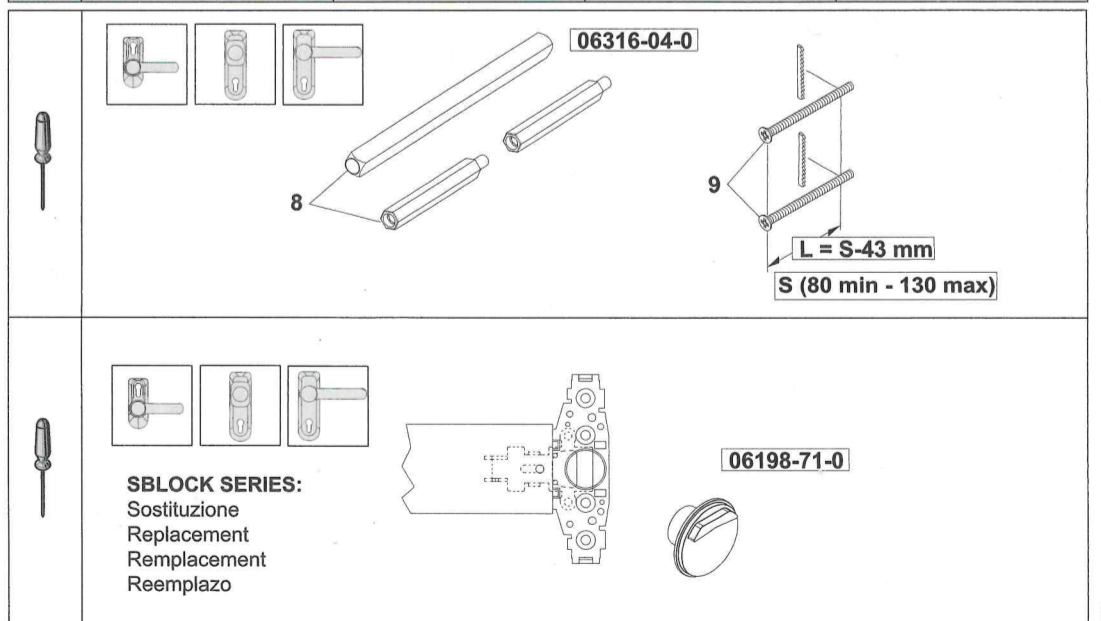

I prodotti qui evidenziati sono dotati di tutte le caratteristiche indicate nella descrizione tecnica dei cataloghi CISA S.p.A. e sono consigliati solamente per gli scopi ivi precisati. La società CISA S.p.A. non garantisce nessuna prestazione o caratteristica tecnica che non sia indicata su queste istruzioni. NON possono essere apportate al prodotto modifiche diverse da quanto espressamente indicato da CISA pena il decadimento degli obblighi di garanzia previsti dalla legge e delle eventuali certificazioni di conformità di prodotto. Per particolari esigenze di sicurezza si invita l'utente a rivolgersi al rivenditore o installatore di questi prodotti ovvero direttamente alla CISA, i quali potranno meglio consigliare il modello più appropriato alle specifiche esigenze del cliente.

The products illustrated in this instruction sheet have all the technical characteristics described in CISA S.p.A. catalogues and are to be used exclusively for the purposes indicated therein. CISA will not guarantee any performance or technical feature which is not expressly mentioned in this instruction sheet. No modifications can be made to the product different from those expressly indicated by CISA without forfeiting the guarantee provided by law and any product compliance certifications. For any specific security requirements, inquire directly with CISA or its authorized dealers or installers about the most suitable product to install.

Les produits présentés ici possèdent toutes les caractéristiques indiquées dans la description technique des catalogues CISA S.p.A. et sont conseillés exclusivement pour les usages prévus. La société Cisa S.p.A ne garantit aucune performance ni caractéristique technique autre que celles qui sont indiquées dans ces instructions ; il ne peut être apporté au produit aucune modification hormis celles qui sont expressément indiquées par CISA, sous peine d'annulation de la garantie légale et des éventuelles certifications de conformité du produit. En cas d'exigences de sécurité particulières, l'utilisateur est invité à s'adresser au revendeur ou à l'installateur de ces produits ou bien directement à CISA, afin d'obtenir les conseils les mieux adaptés à ses exigences spécifiques.

Los productos descritos poseen todas las características indicadas en la descripción técnica de los catálogos CISA S.p.A. y están recomendados solamente para los fines allí indicados. La sociedad CISA S.p.A. no garantiza ninguna prestación o característica técnica que no esté indicada en estas instrucciones. No está permitido realizar modificaciones en el producto diferentes a las indicadas expresamente por CISA, bajo pena de caducidad de las obligaciones de garantía previstas por la ley, así como de las eventuales certificaciones de conformidad del producto. En caso de particulares exigencias de seguridad, se invita al usuario a contactar con el revendedor o instalador de los productos, o directamente con CISA, quienes podrán aconsejarle el modelo más adecuado.