



# WEEN

## KIT CERNIERE ANTA AFFIANCATA ERRE40



Kit Cerniere e braccio Ween per anta affiancata | Passive sash Ween hinge and arm | Charnières et bras pour dormant | Bisagras y compás para hoja pasiva



Cerniere in estruso e zama, contropiastre e viti; braccio con leva, viti e grani in acciaio inox, corpo in zama.



Extruded aluminum and zamak hinges, counterplates and screws; arm lever, screws and setscrews in stainless steel, zamak body.



Charnières en aluminium extrudé et zamak, gâches et vis; bras levier, vis et grains en acier inox, corps en zamak.



Bisagras de aluminio extruido y zamac, cerraderos y tornillos; Compás con leva tornillos y prisioneros de acero inox, cuerpo de zamac.



ART.	3421.23			
Imballo   Package   Conditionnement   Embalaje	5 Pz			
Finiture disponibili   Available finishes Finitions disponibles   Acabados disponibles	1	2	3	4

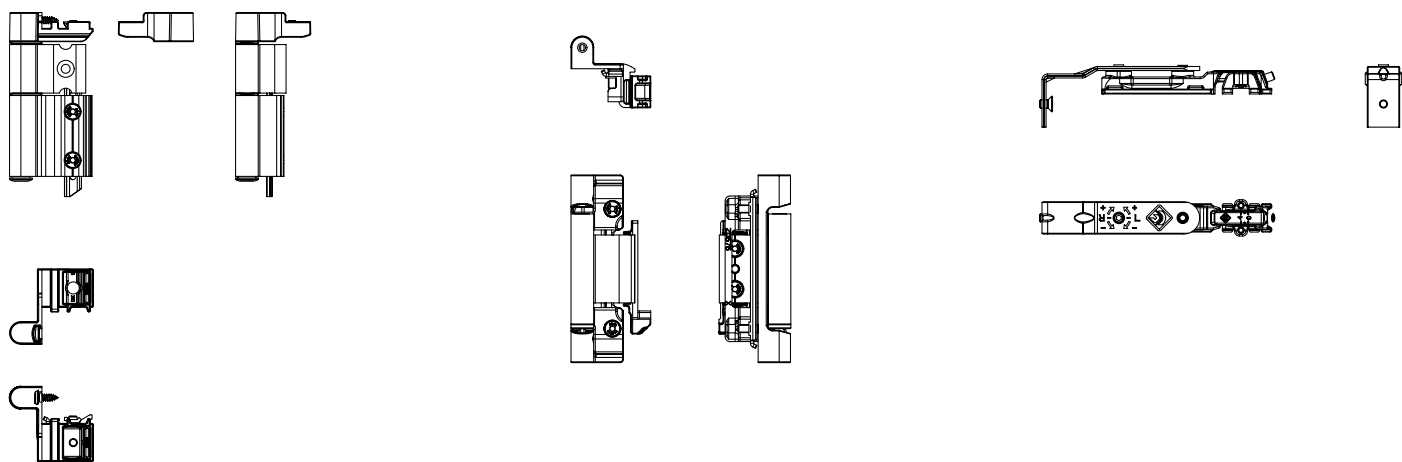

### REGOLAZIONI | ADJUSTEMENT

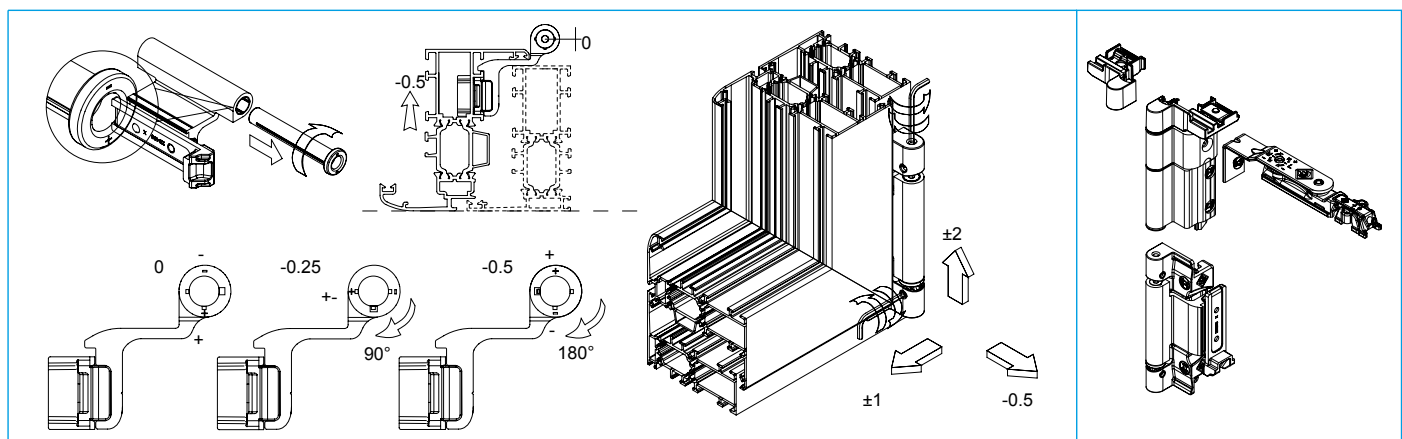

ART.	NODO SECTION
3421.23	A08

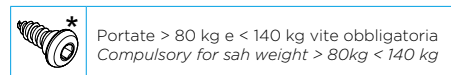
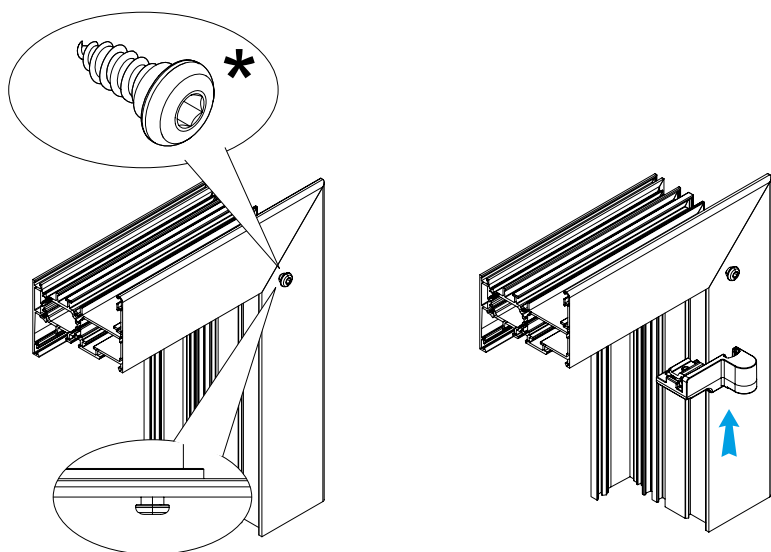

TABELLA DI CARICO | LOAD CHART

PESO MASSIMO DELL'ANTA (alluminio + vetro = 140 Kg) MAXIMUM WEIGHT OF THE SASH (aluminium + glass =140 Kg)									
Spessore max. del vetro indicato (es. 30 mm) Maximum thickness of the glass (es. 30 mm)					N.D. = Dimensione Non Disponibile N.D. = Dimension Not Available				
Nota: Lo spessore massimo del vetro impiegabile si riferisce al materiale senza la camera d'aria Note: The maximum thickness of the glass is considered without the air-space									
2700	50	41	35	30	26	23	21	19	17
2600	50	43	36	31	27	24	22	20	18
2500	50	45	37	32	28	25	22	20	19
2400	50	47	39	33	29	26	23	21	19
2300	50	49	41	35	30	27	24	22	20
2200	50	50	42	36	32	28	25	23	21
2100	50	50	44	38	33	30	27	24	22
2000	50	50	47	40	35	31	28	25	23
1900	50	50	49	42	37	33	29	27	25
1800	50	50	50	44	39	35	31	28	26
1700	50	50	50	47	41	37	33	30	27
1600	50	50	50	50	44	39	35	32	29
1500	50	50	50	50	47	41	37	34	31
1400	50	50	50	50	50	44	40	36	30
1300	50	50	50	50	50	48	43	35	32
1200	50	50	50	50	50	50	42	38	35
1100	50	50	50	50	50	50	46	42	32
1000	50	50	50	50	50	50	50	38	28
900	50	50	50	50	50	50	37	34	21
800	50	50	50	50	50	47	42	25	12
700	50	50	50	50	50	50	16	x	x
600	50	50	50	50	47	21	x	x	x
500	50	50	50	50	x	x	x	x	x
H \ L	395	500	600	700	800	900	1000	1100	1200