

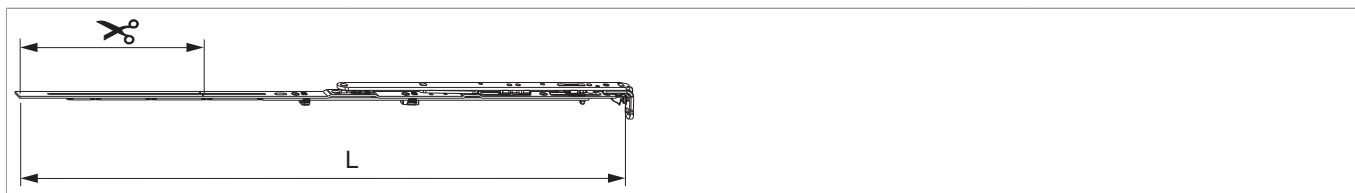







211678 - Forbice ad angolo premontata MM per aerazione sinistro 800 LBB 601-800 argento

Disegni tecnici



							L		Nº
argento	sinistro	Forbice ad angolo premontata MM	800	601 - 800	491 - 690	210	696,5	20	211678 ¹⁾

¹⁾ Usare solo in combinazione con movimento angolare con bifungo orizzontale (con scontro ribalta verticale per bilanciere il battente può essere scavalcata).

Tabella posizionamento viti

Nº		1	2	3	4	5	6	
211678	4	18,5	91,5	250	377			

Tabella punti di chiusura

Nº		Z1	
211678	0		

Schema di tranciatura

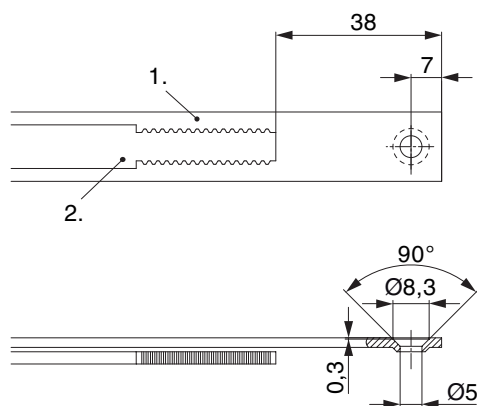

• Consigliamo di trattare il taglio dei componenti TRICOAT-PLUS con la vernice di ritocco TRICOAT-PLUS (cod. 358440).

1. Frontale

2. Asta mobile

Collegamento a clips

Agganciare collegamenta a clips

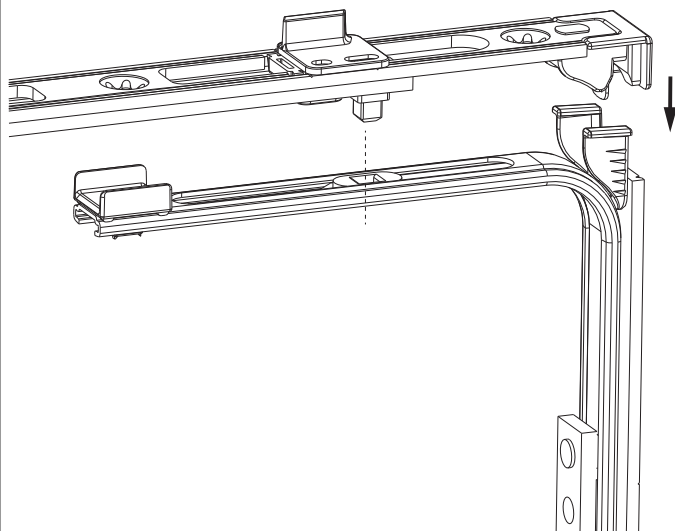

Sganciare collegamento clips

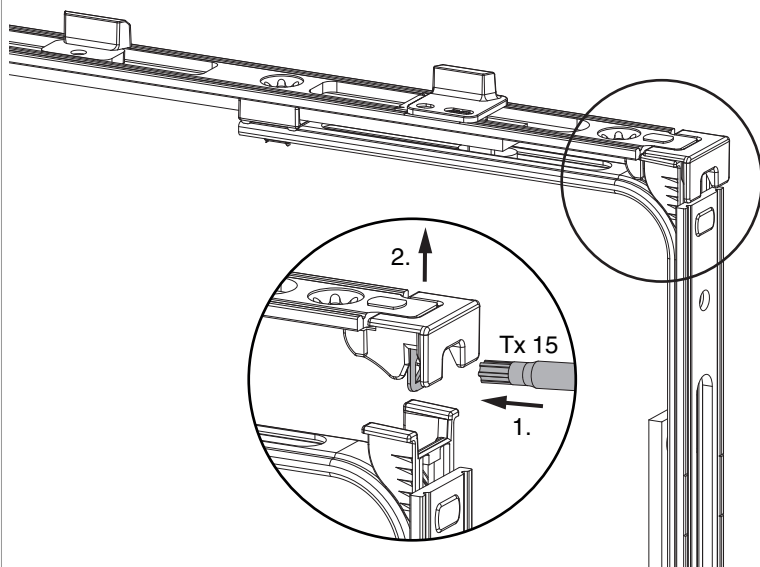

Collegamento scarpetta dentata

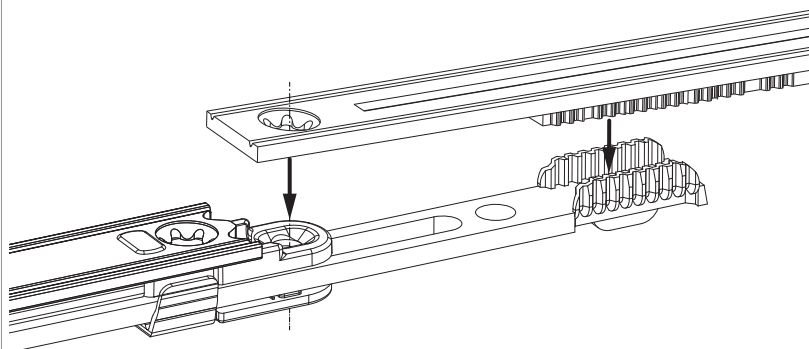

Raggio di ribalta

Posizione di ribalta / aereazione controllata

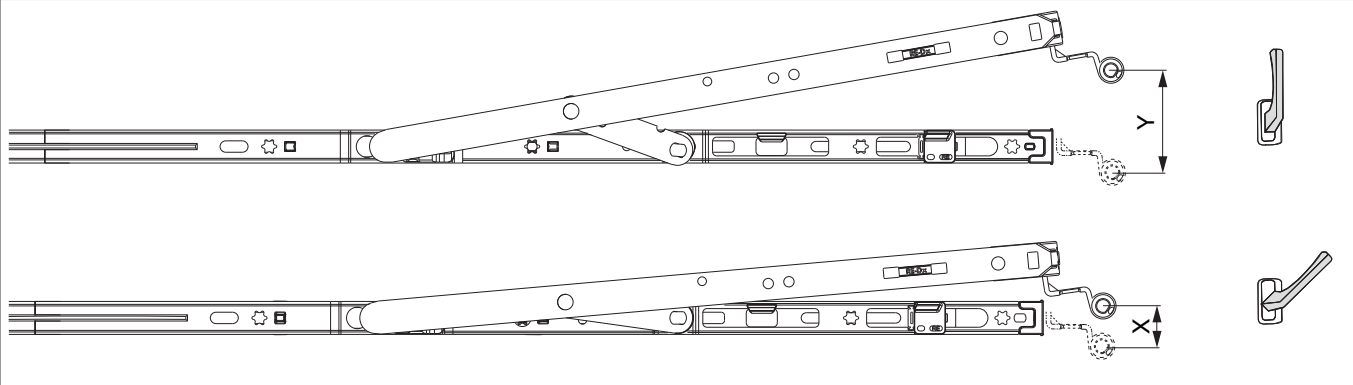

	X	Y
400	~ 13	80
600	~ 13	120
800	~ 13	125
1050	~ 13	127
1300	~ 13	127

Regolazione laterale

nel braccio forbice

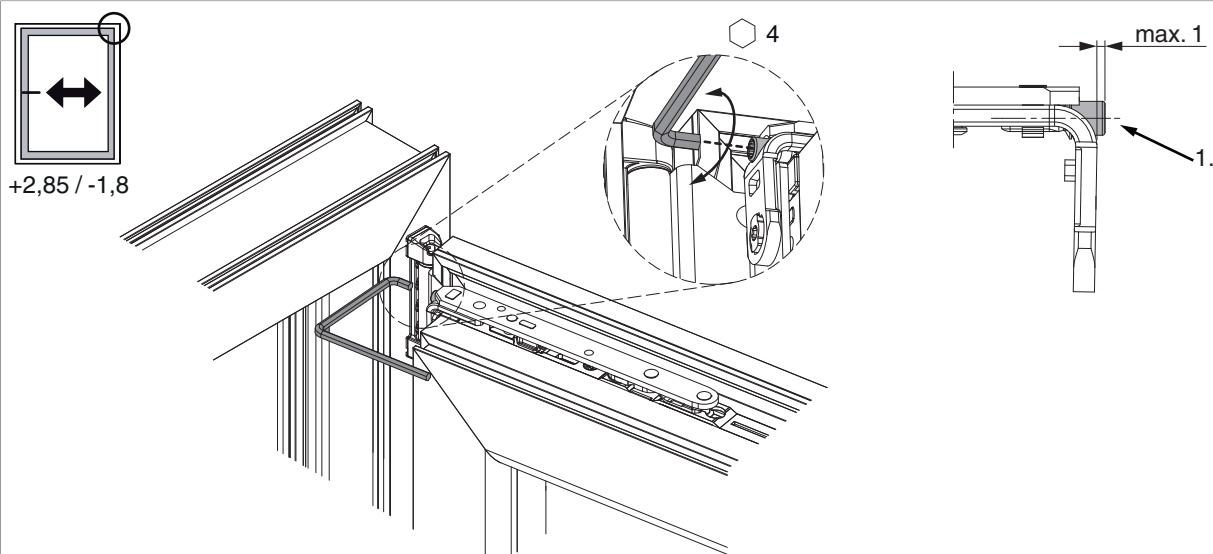

1. Durante l'abbassamento dell'anta assicurarsi che la vite non fuoriesca completamente. La testa della vite deve sporgere al massimo 1 mm!

Regolazione pressione

nel braccio forbice

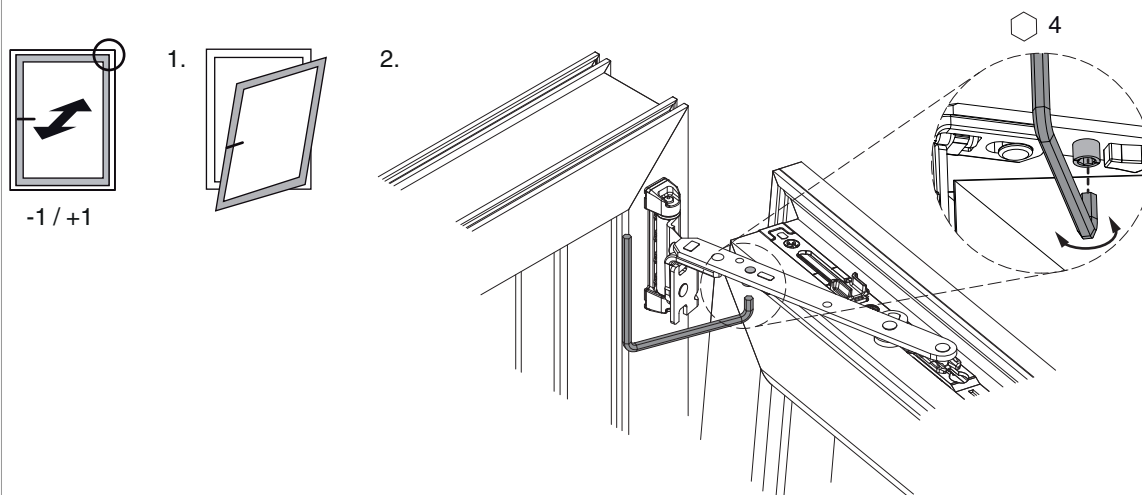

Fungo e nottolino

