

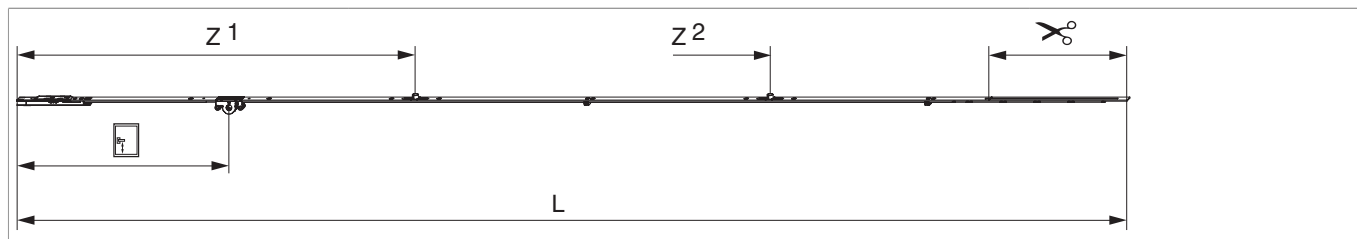

212726 - Cremonese ad inversione Multi Matic 2200 E15 con 2 nottolini HBB 1.951-2.200 HM500 argento

Disegni tecnici



		L						N°
argento	2200	2.096,5	15	500	1.951 - 2.200	260,5	10	212726

Tabella posizionamento viti

N°		1	2	3	4	5	6	7	8	9	10	
212726	10	28	119,5	315	574	705	795	1.085	1.375	1.465	1.729	

Tabella punti di chiusura

N°		Z1	Z2	
212726	2	750	1.420	

Dime

			N°
Dima forature per fori martellina MM	per punta 3mm	1	203861
Dima forature per fori martellina MM	per punta D=3 mm e D=12 mm	1	203862

Quote della scatola cremonese



- Larghezza fresata per scatola cremonese 12 mm
- Per fissaggio maniglia utilizzare viti SPAX Ø 5 mm o viti M5.

Schema di foratura

Per serramenti in legno

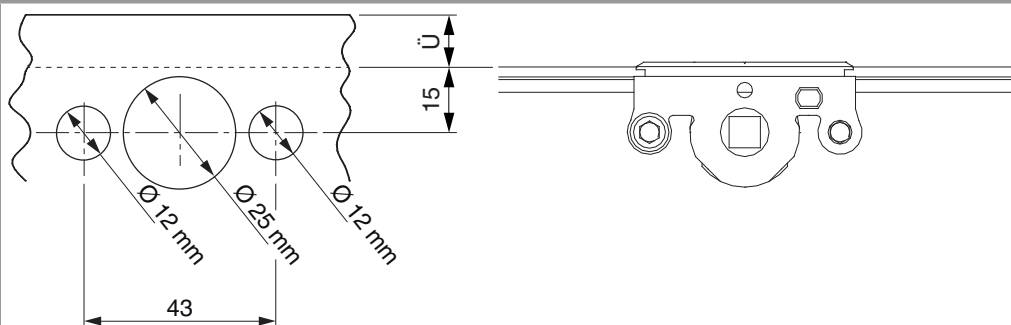

Per serramenti in PVC e alluminio

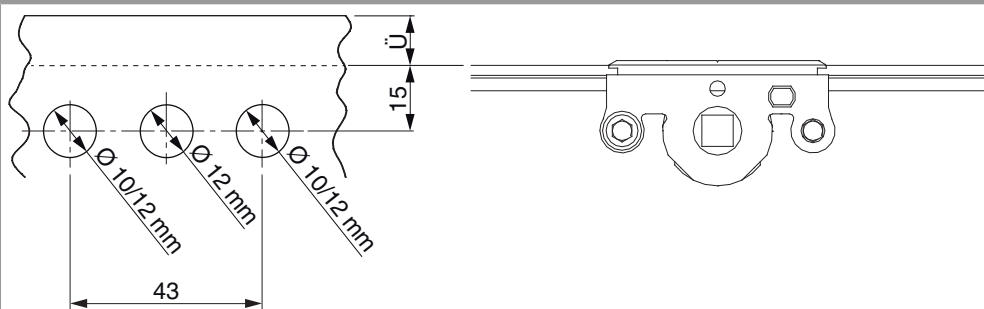

Regolazione uscita puntale (a scelta 11 o 14 mm)

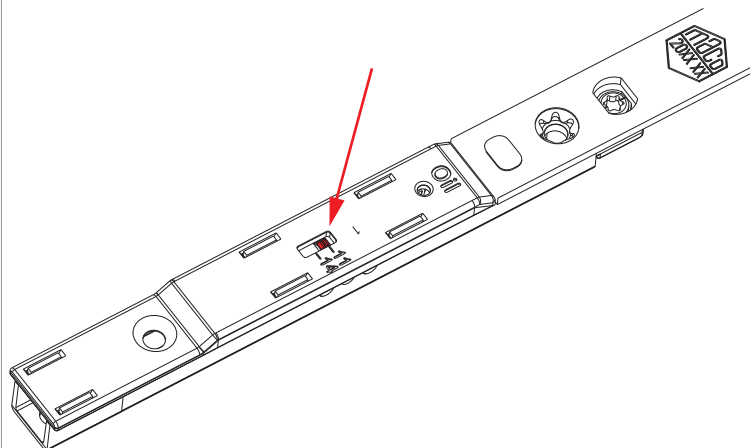

Impostazione di base uscita puntale 11 mm

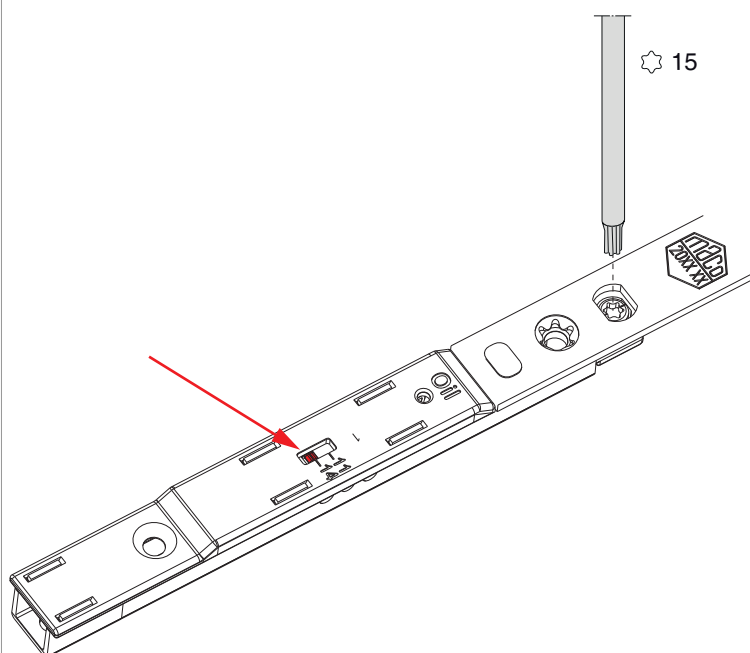

Regolazione del perno eccentrico
Uscita puntale 14 mm

Schema di tranciatura

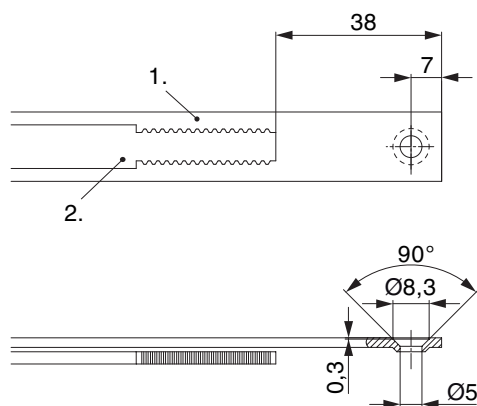

• Consigliamo di trattare il taglio dei componenti TRICOAT-PLUS con la vernice di ritocco TRICOAT-PLUS (cod. 358440).

- 1. Frontale
- 2. Asta mobile

Collegamento scarpetta dentata

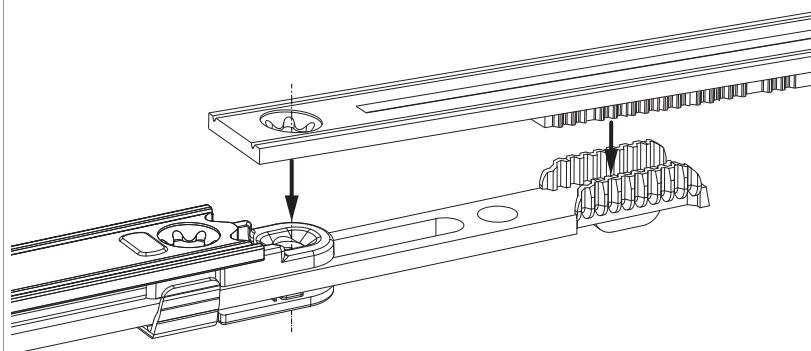

Regolazione pressione

Fungo e nottolino

