

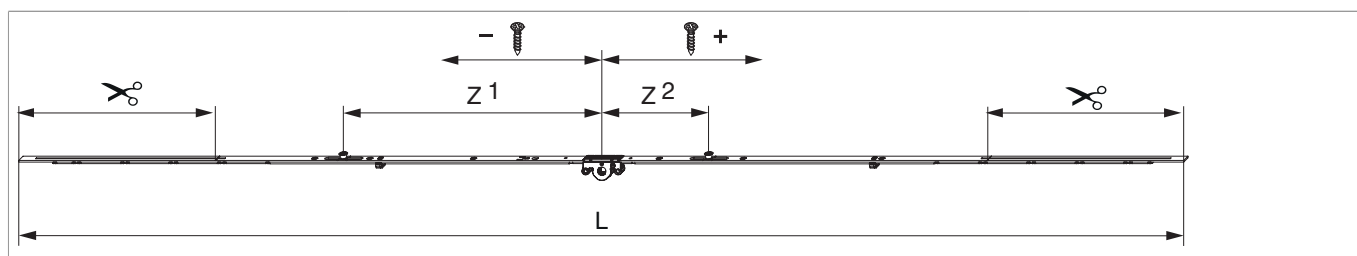

202171 - Cremonese A-B Multi Matic 1750 E15 variabile con 2 funghi HBB 1.251-1.750 argento

Disegni tecnici







		L					Nº
argento	1750	1.540	15	1.251 - 1.750	260	10	202171

Tabella posizionamento viti



Nº		1	2	3	4	5	6	7	8
202171	6	-381,5	-308,5	-171,5	74	185	368,5		

Tabella punti di chiusura

Nº		Z1	Z2	Z3
202171	2	-343	140	

Dime

			Nº
Dima forature per fori martellina MM	per punta 3mm	1	203861
Dima forature per fori martellina MM	per punta D=3 mm e D=12 mm	1	203862

Quote della scatola cremonese

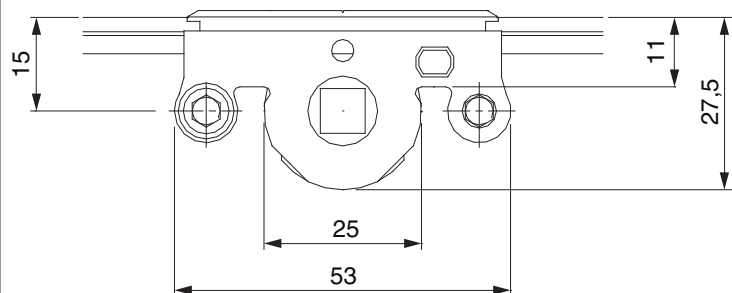

- Larghezza fresata per scatola cremonese 12 mm
- Per fissaggio maniglia utilizzare viti SPAX Ø 5 mm o viti M5.

Schema di fresata

per PVC e alluminio

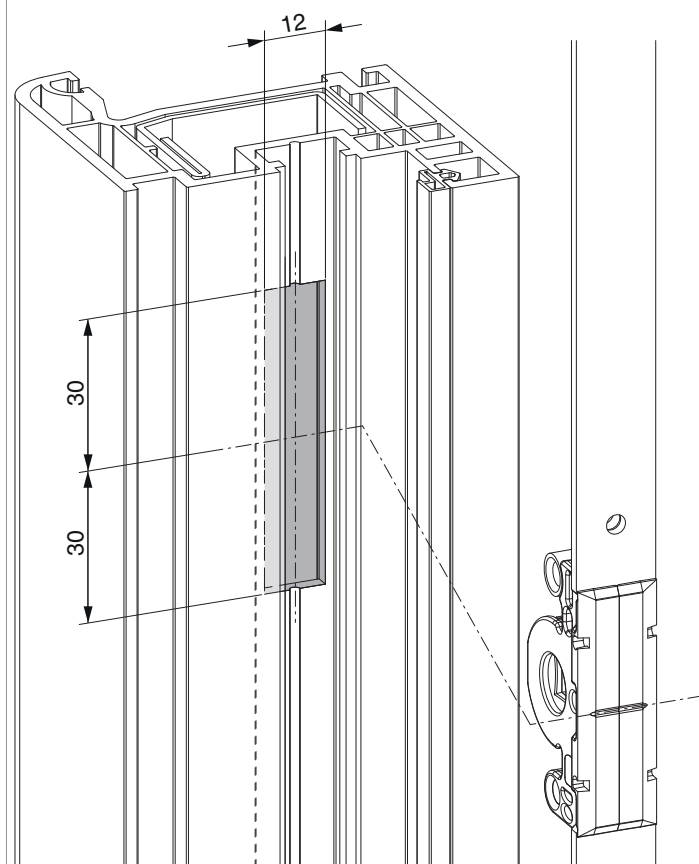

Schema di foratura

Per serramenti in legno

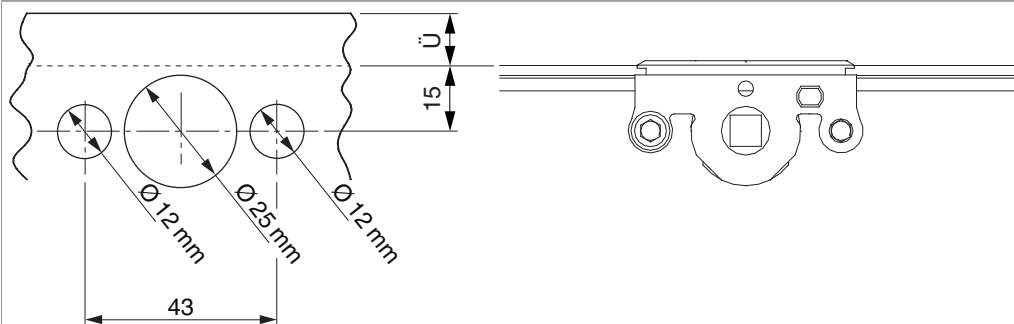

Per serramenti in PVC e alluminio

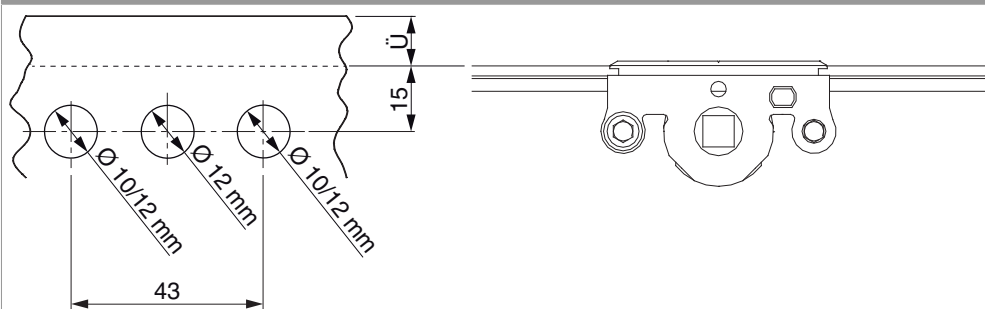

Schema di tranciatura

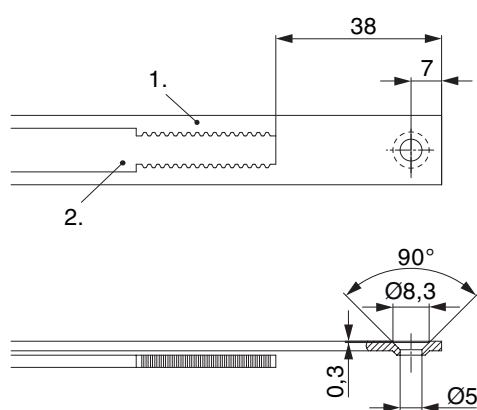

• Consigliamo di trattare il taglio dei componenti TRICOAT-PLUS con la vernice di ritocco TRICOAT-PLUS (cod. 358440).

1. Frontale
2. Asta mobile

Collegamento scarpetta dentata

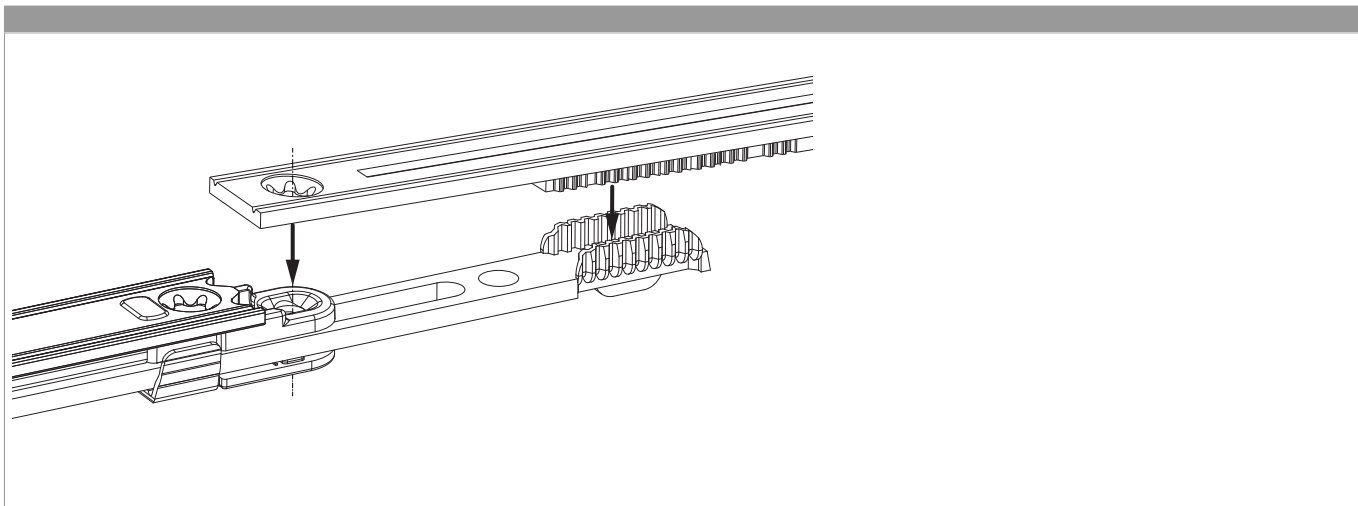

Regolazione pressione

Fungo e nottolino

