

218505 - Cremonese ad inversione Multi Matic 1950 E15 con 2 nottolini HBB 1.701-1.950 HM500 argento

Disegni tecnici

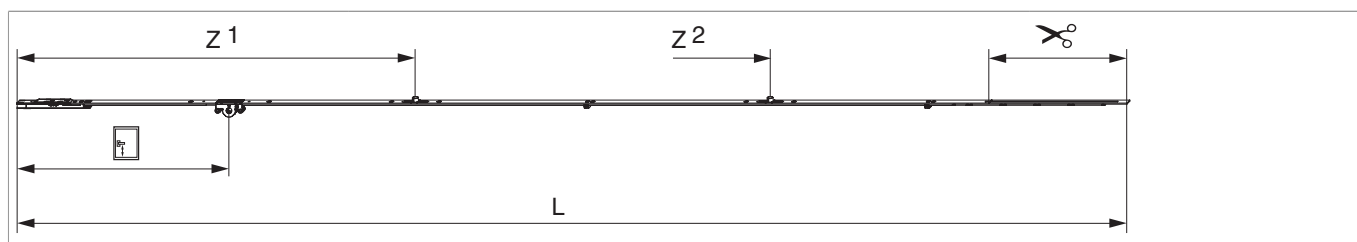

argento	1950	1.846,5	15	500	1.701 - 1.950	260,5	10	218505

Tabella posizionamento viti

No.		1	2	3	4	5	6	7	8	9	10
218505	10	28	119,5	315	550	705	795	863,5	1.124	1.388	1.465

Tabella punti di chiusura

No.		Z1	Z2
218505	2	750	1.420

Quote della scatola cremonese

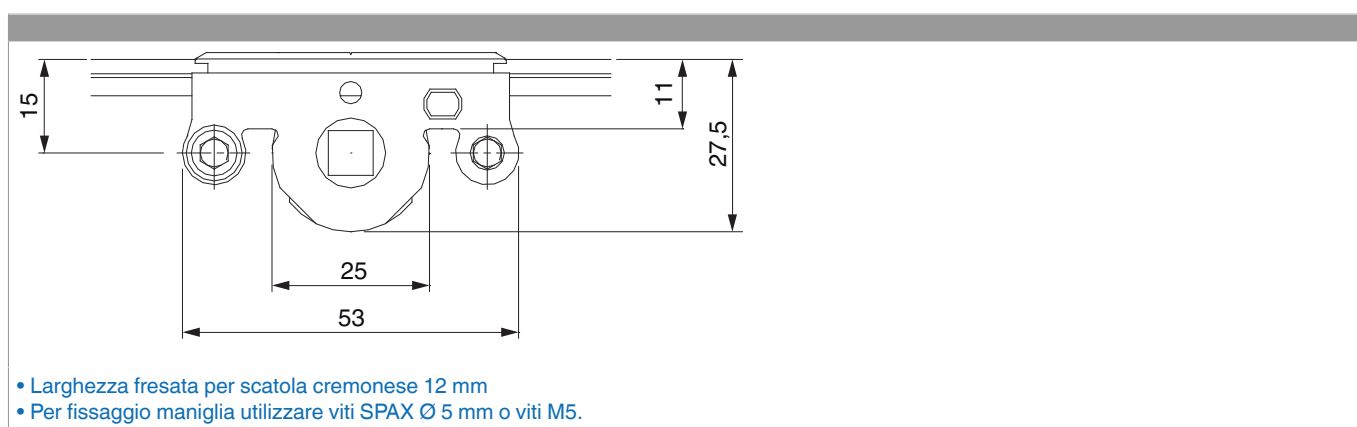

Schema di foratura

Per serramenti in legno

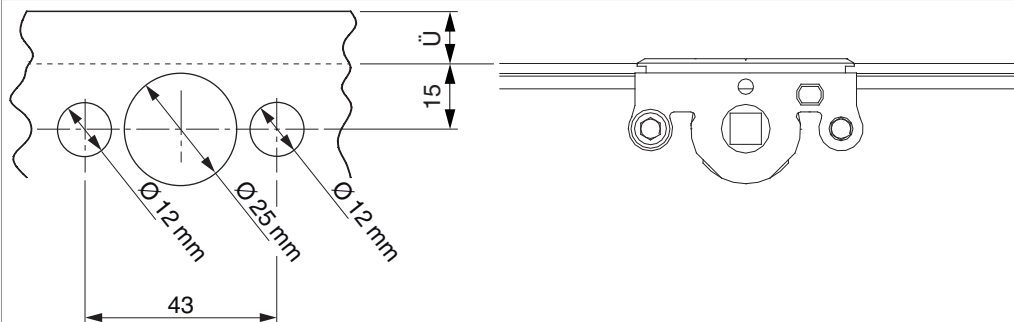

Per serramenti in PVC e alluminio

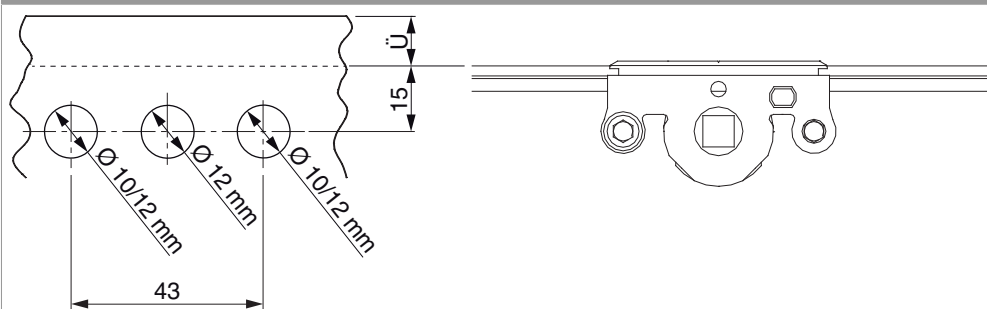

Regolazione uscita puntale (a scelta 11 o 14 mm)

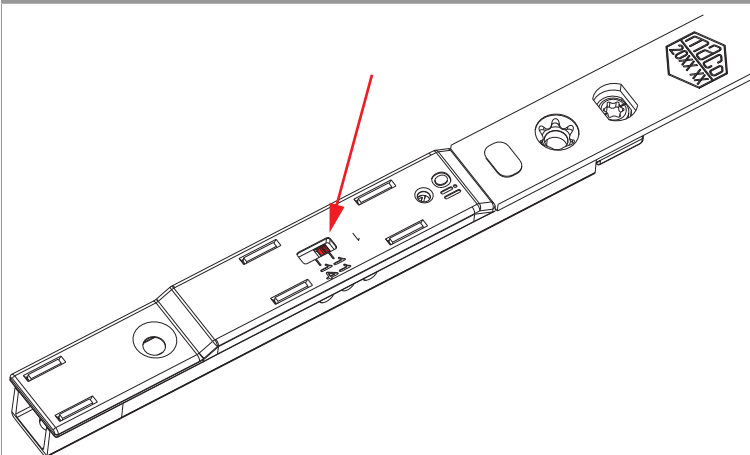

Impostazione di base uscita puntale 11 mm

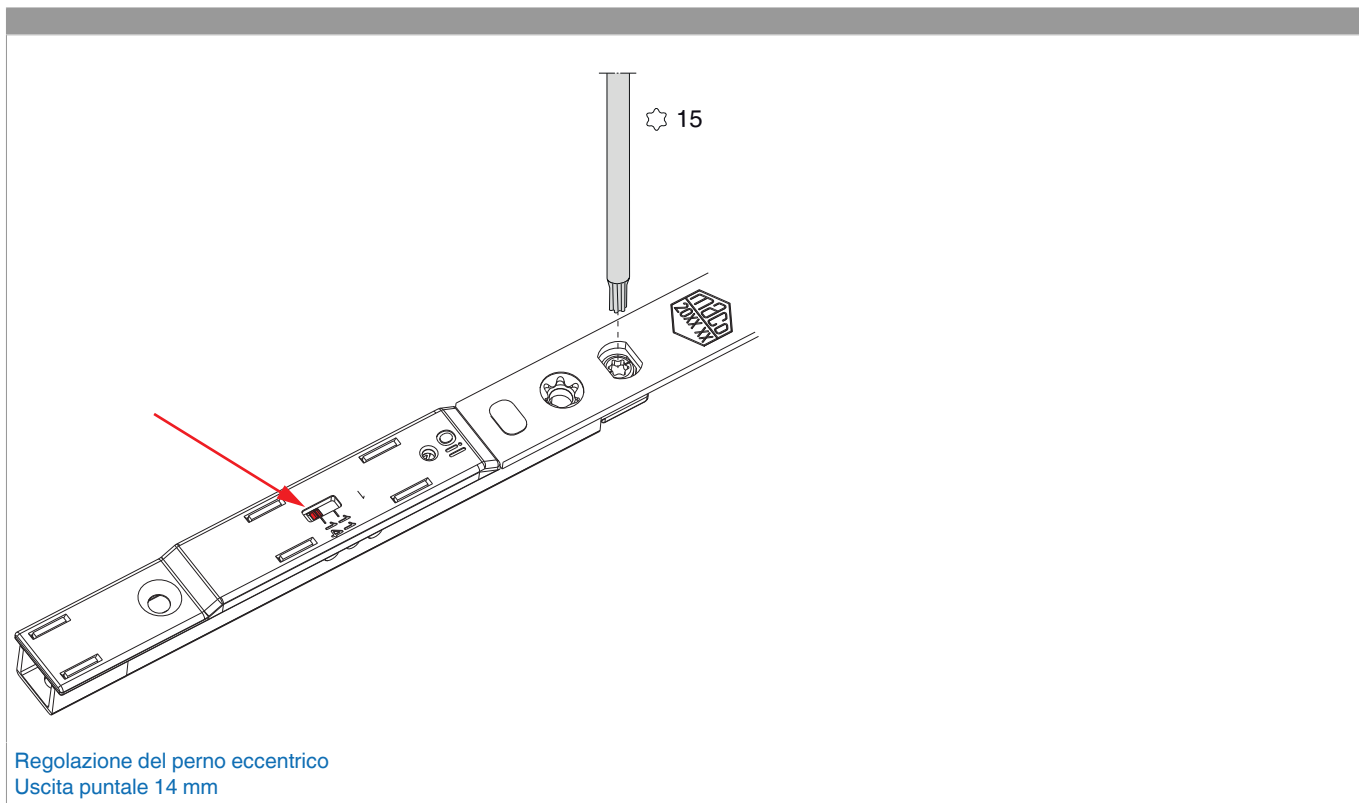

Schema di tranciatura

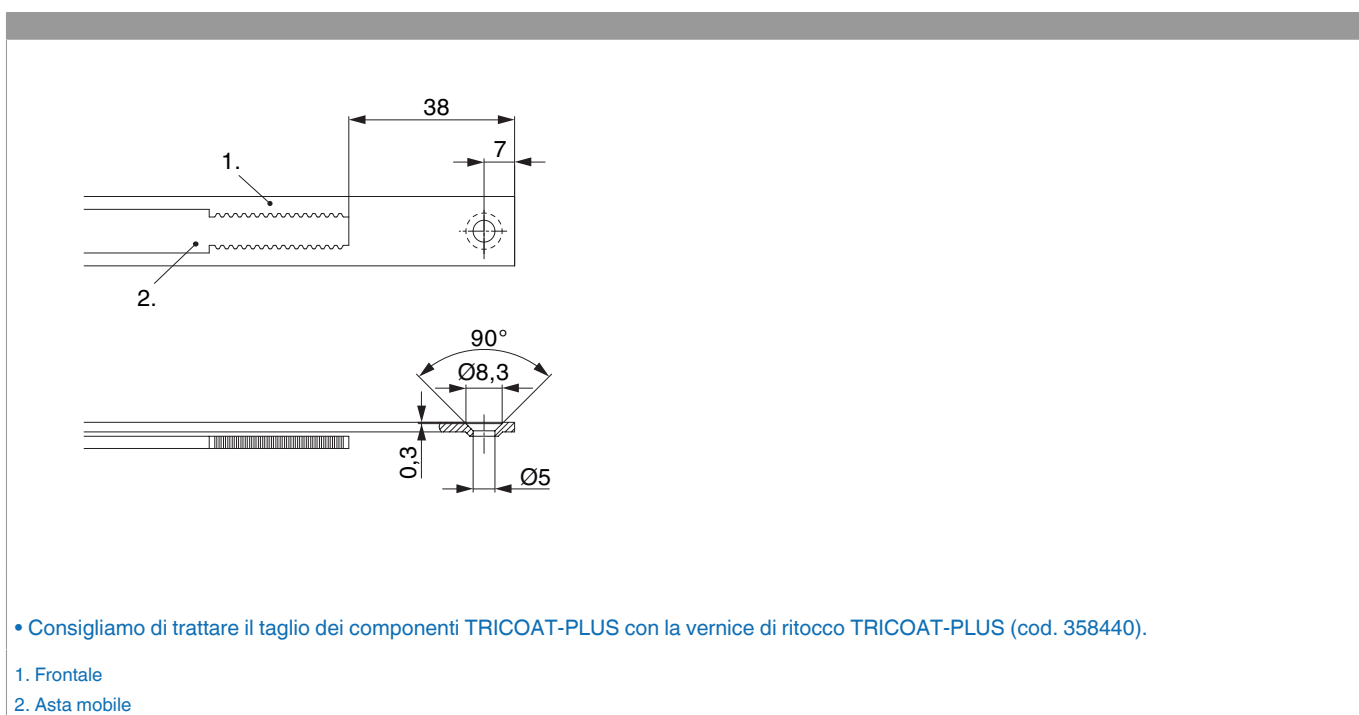

Collegamento scarpetta dentata

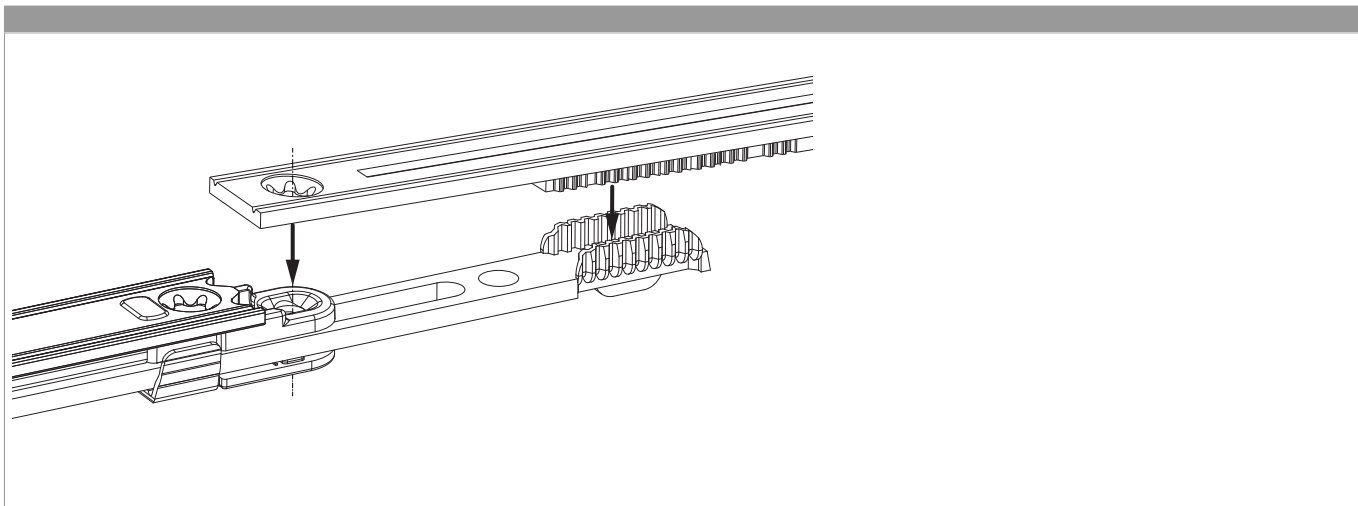

Regolazione pressione

