

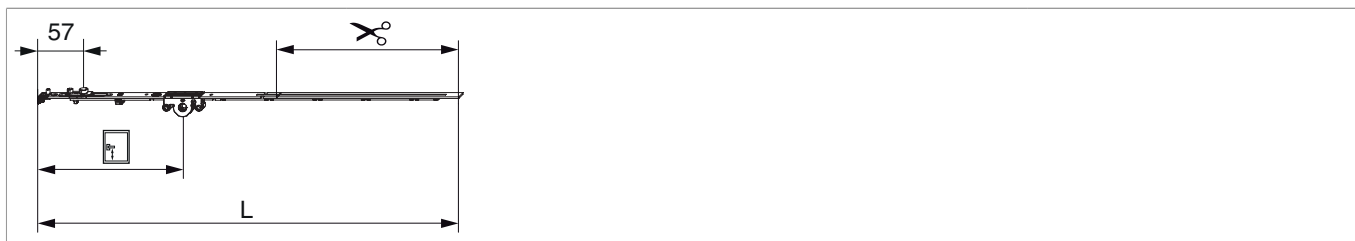

209371 - Cremonese A-B Multi Matic 660 E15 fix con bilanciere HBB 431-660 HM190 argento

Disegni tecnici



			L							Nº
argento		660	556,5	15	190	431 - 660	240,5	-	20	209371 ¹⁾

¹⁾ Per l'avvitamento del frontale usare il fermo per frontale (cod. 213287)

Tabella posizionamento viti

Nº		1	2	3	4	5	6	7	8	9	10	11	12	13	14
209371	2	18,5	91,5												

Tabella punti di chiusura

Nº		Z1	Z2	Z3	Z4
209371	0				

Dime

							Nº
Dima fresa per finestra a 2 ante	legno	catenaccio	fresa 16/anello 27	Aria 4		1	21598
Dima forature per fori martellina MM			per punta 3mm			1	203861
Dima forature per fori martellina MM			per punta D=3 mm e D=12 mm			1	203862
Dima completa con guidascontro per cremonese fix MM		scontri 48 mm	2 ante	per cava ferramenta	431 - 1.340	1	210983

Quote della scatola cremonese

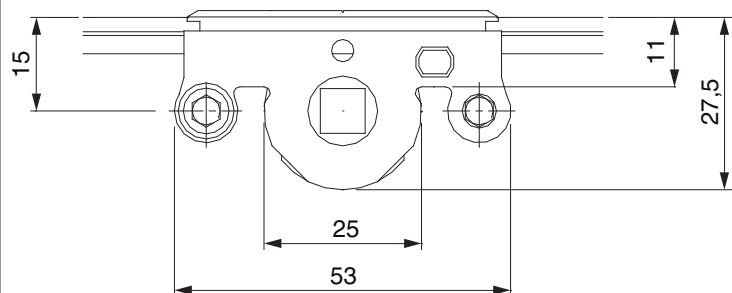

- Larghezza fresata per scatola cremonese 12 mm
- Per fissaggio maniglia utilizzare viti SPAX Ø 5 mm o viti M5.

Schema di fresata

per PVC e alluminio

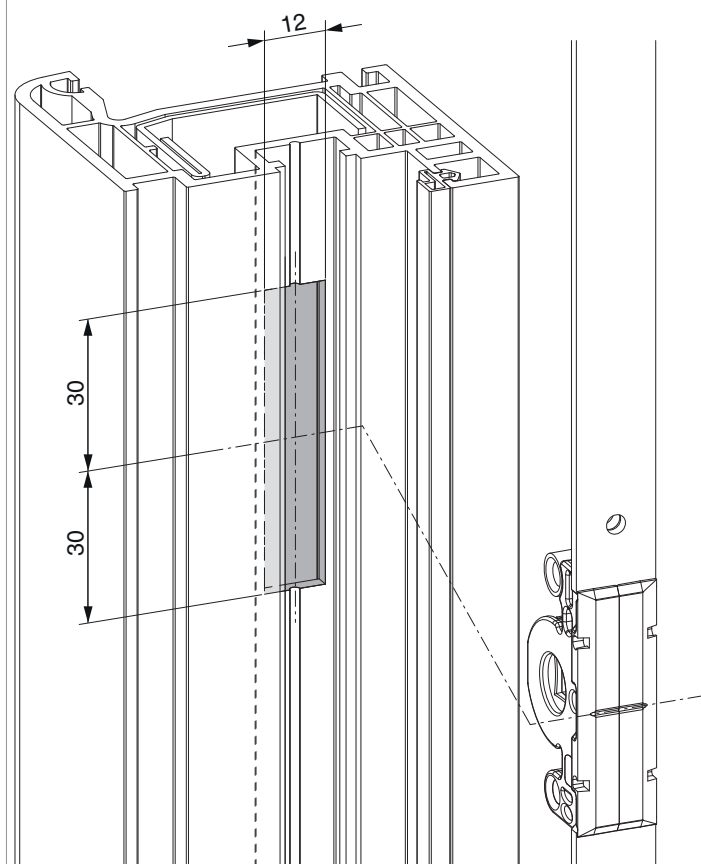

Schema di foratura

Per serramenti in legno

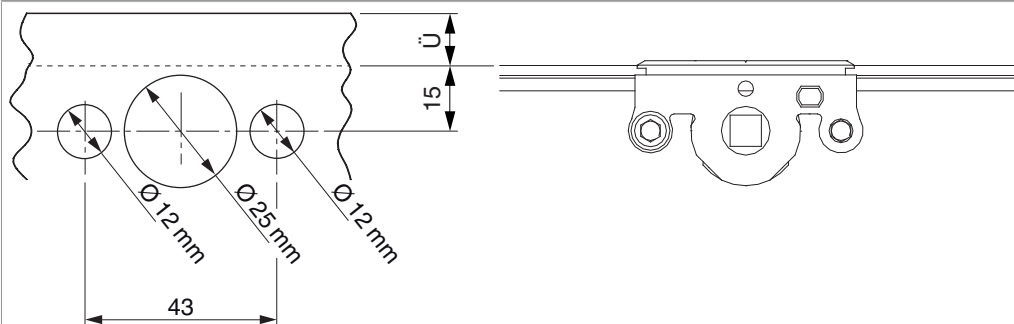

Per serramenti in PVC e alluminio

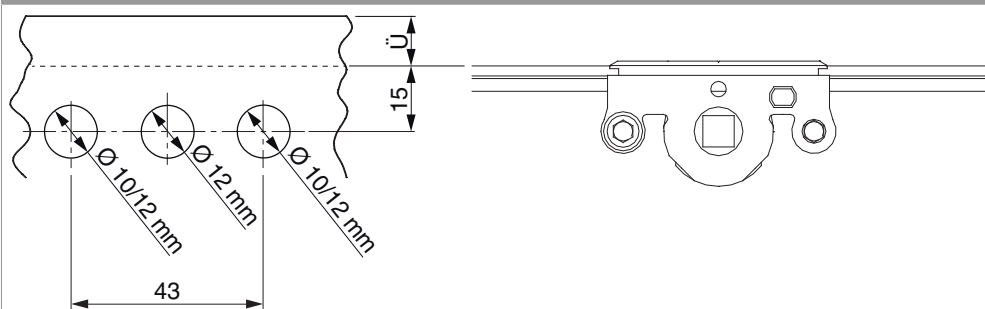

Schema di tranciatura

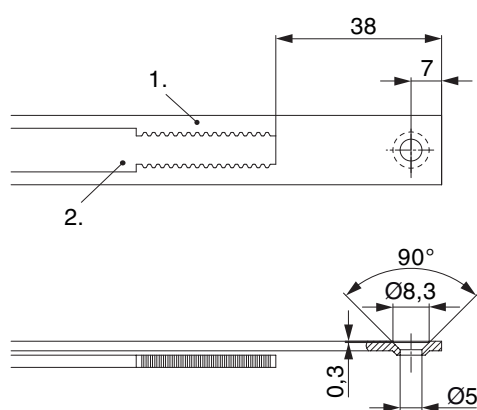

• Consigliamo di trattare il taglio dei componenti TRICOAT-PLUS con la vernice di ritocco TRICOAT-PLUS (cod. 358440).

1. Frontale
2. Asta mobile

Posizionamento scontri alza anta

Scontro alza-anta A4 / senza scrocco porta

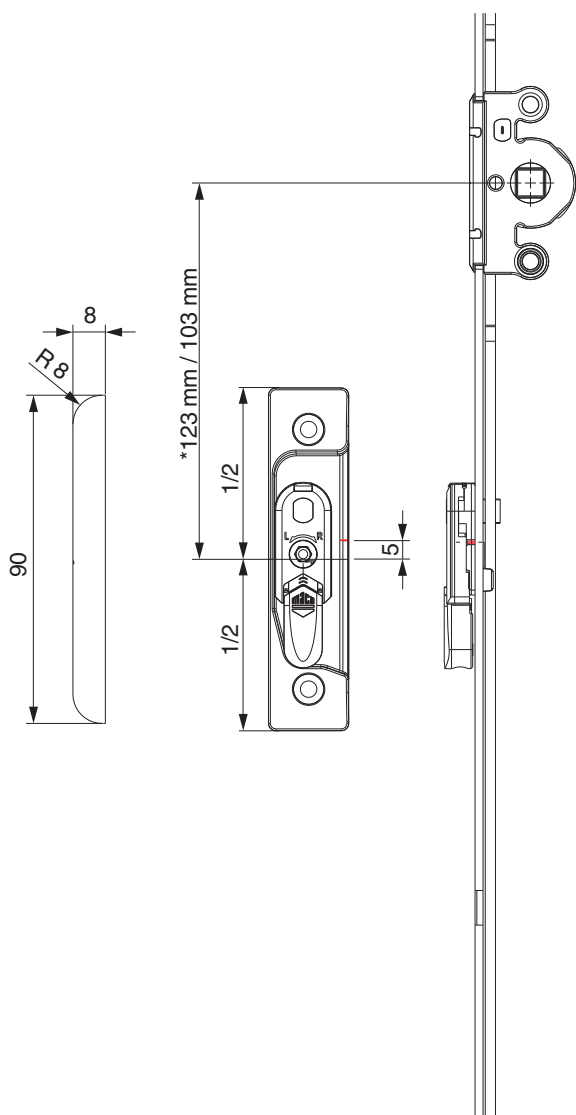

* con cremonesi grandezza 660

Scontro alza-anta A4 / con scrocco porta

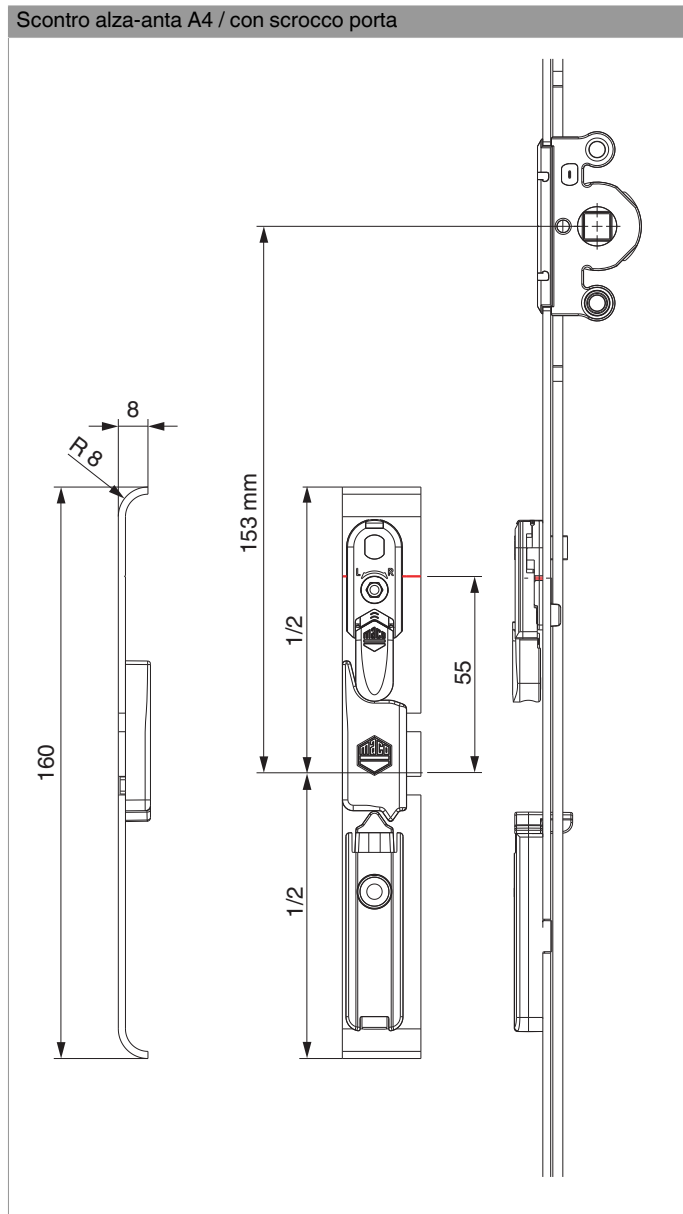

A12

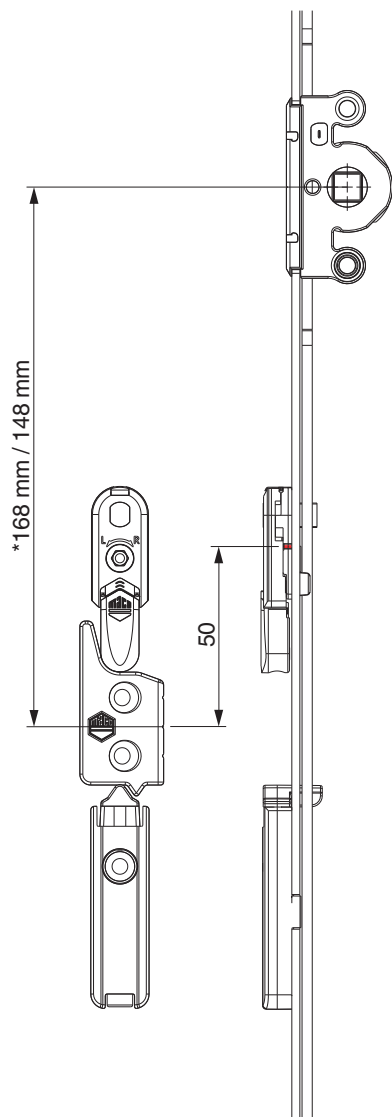

* con cremonesi grandezza 660

Oscillazione e regolazione in altezza dell'alza anta

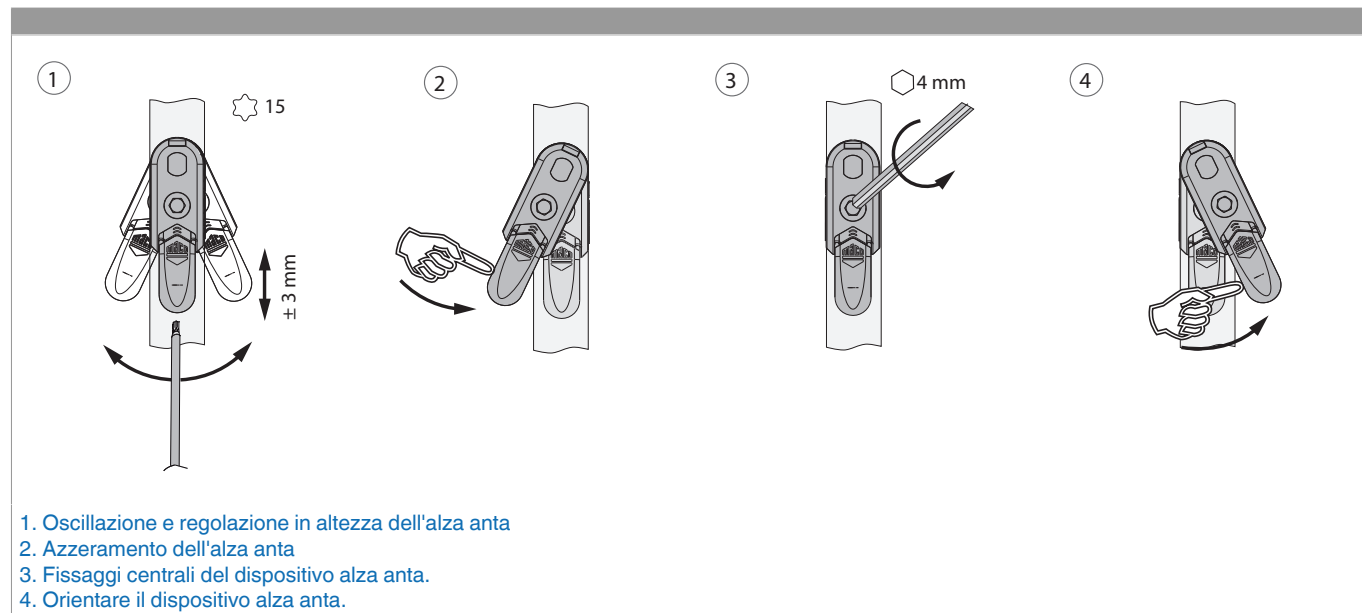

Collegamento a clips per bilanciere

Agganciare collegamenta a clips

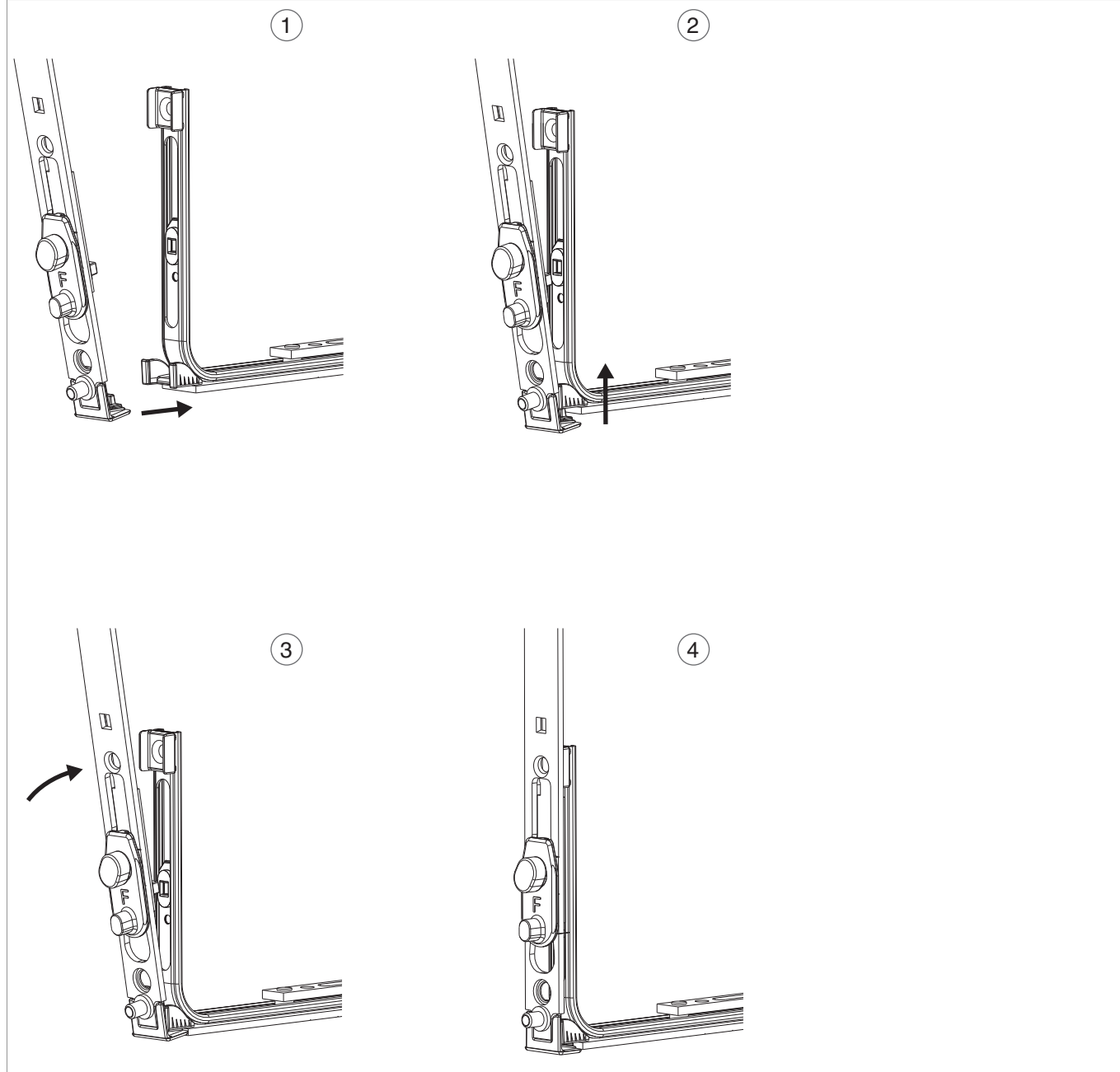

Collegamento scarpetta dentata

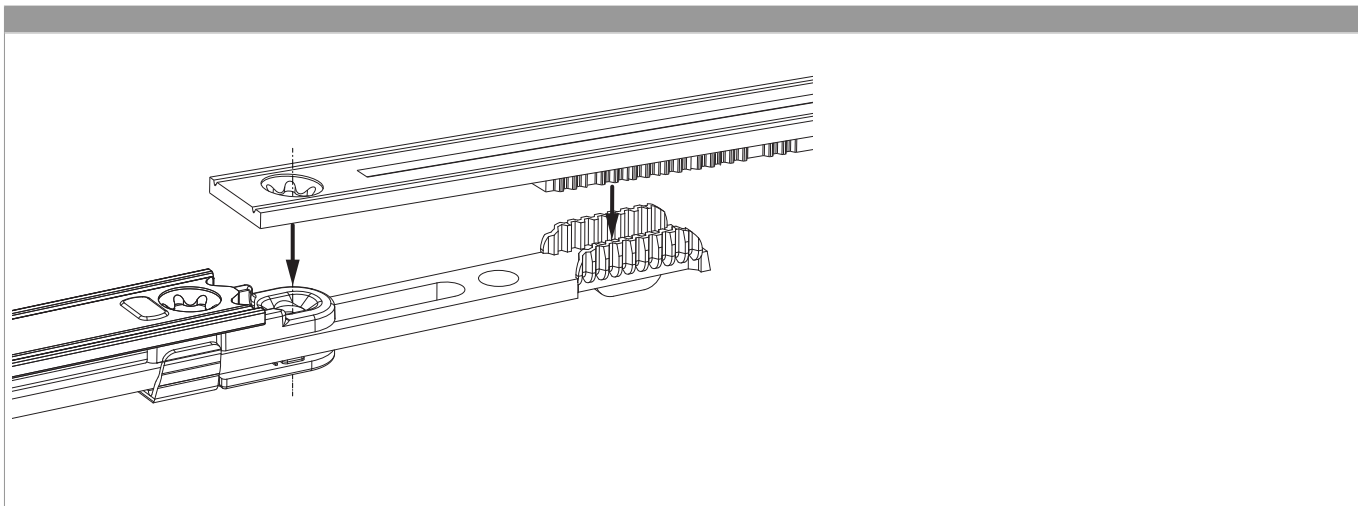

Posizione nottolino al bilanciere

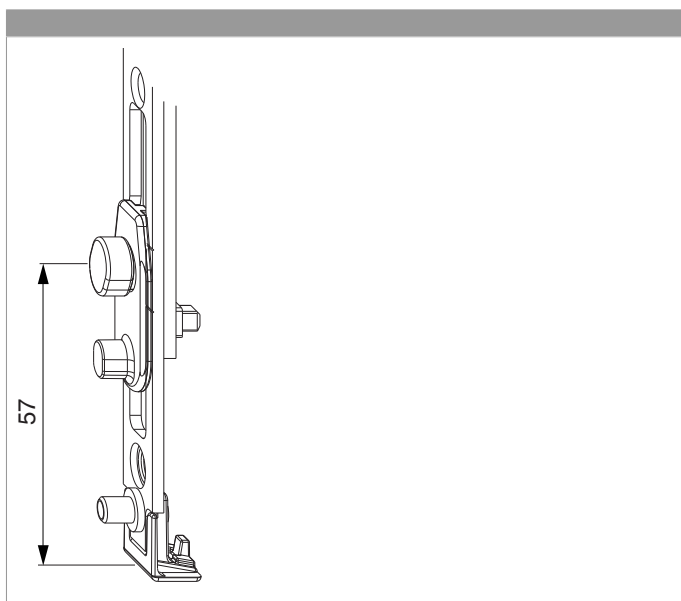

Regolazione in pressione su bilanciere

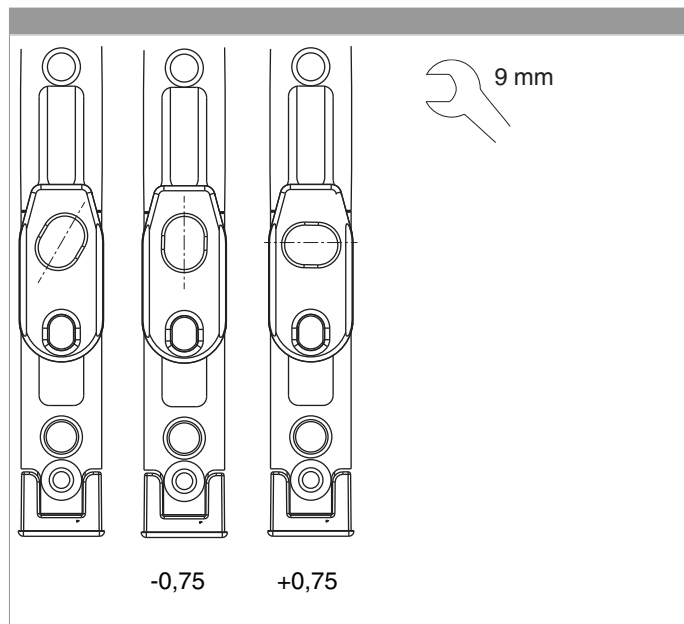

Regolazione pressione

