

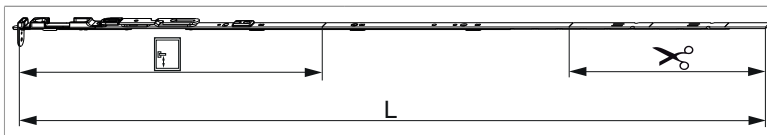

## 211802 - Asta a leva MM 'euronut' su tre ante fix 1950 HBB 1.701-1.950 sinistro HM 1.050 argento

### Disegni tecnici



				<b>L</b>				<b>No</b>
argento	sinistro	1950	1.050	1.846,5	1.701 - 1.950	260,5	10	211802 <sup>1)</sup>

<sup>1)</sup> Da ordinare separatamente: fermaglio guida (cod. 94035) e fermo per frontale (cod. 94036)! Tipo e quantità dei fissaggi dipendono dalle possibilità del asta a leva dopo il taglio.

### Tabella posizionamento viti

<b>No</b>		1	2	3	4	5	6	7	8	9	10	11	12	13	14	15	16
211802	12	82	145	293,5	359,5	465	649,5	728,5	950	1.150	1.330	1.465					

### Schema di tranciatura

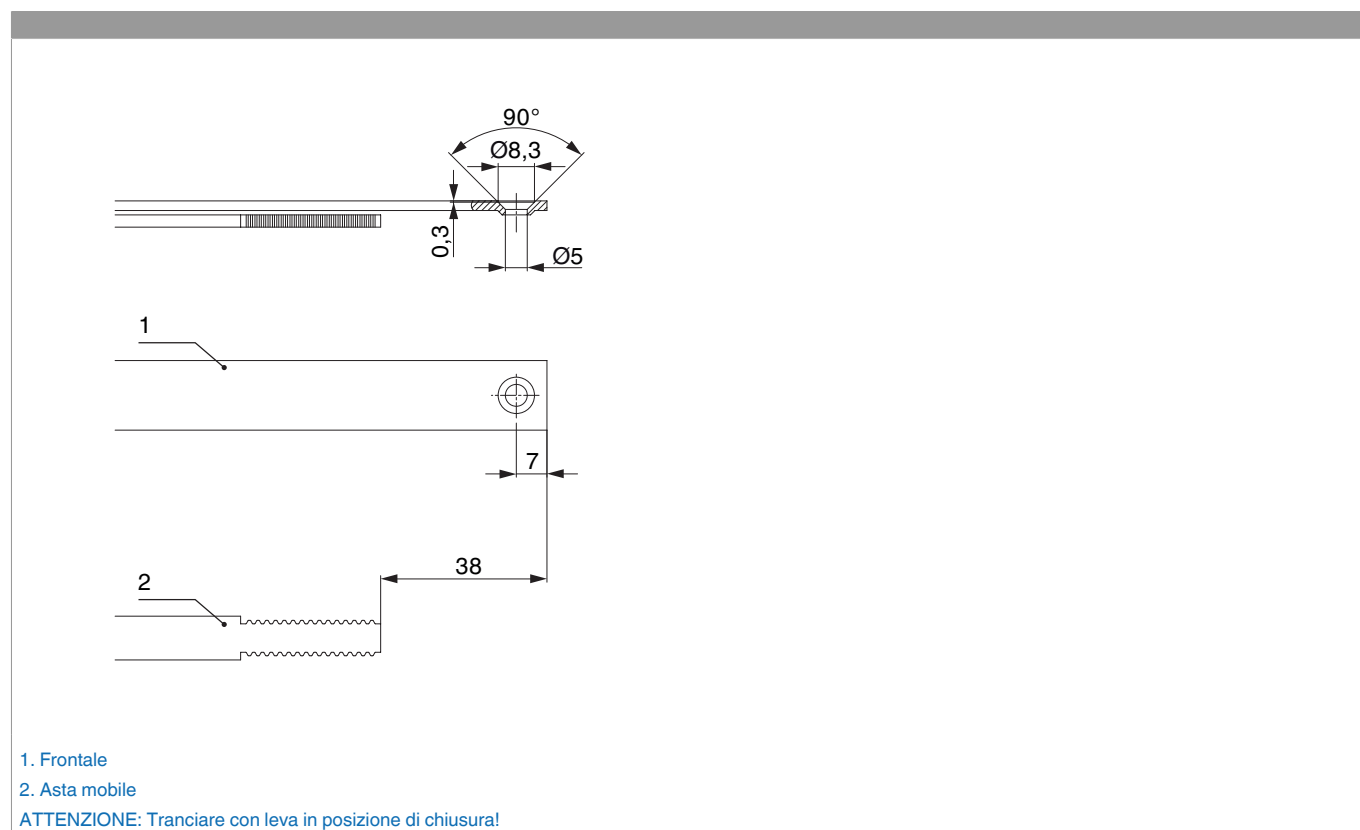



### Uscita puntale

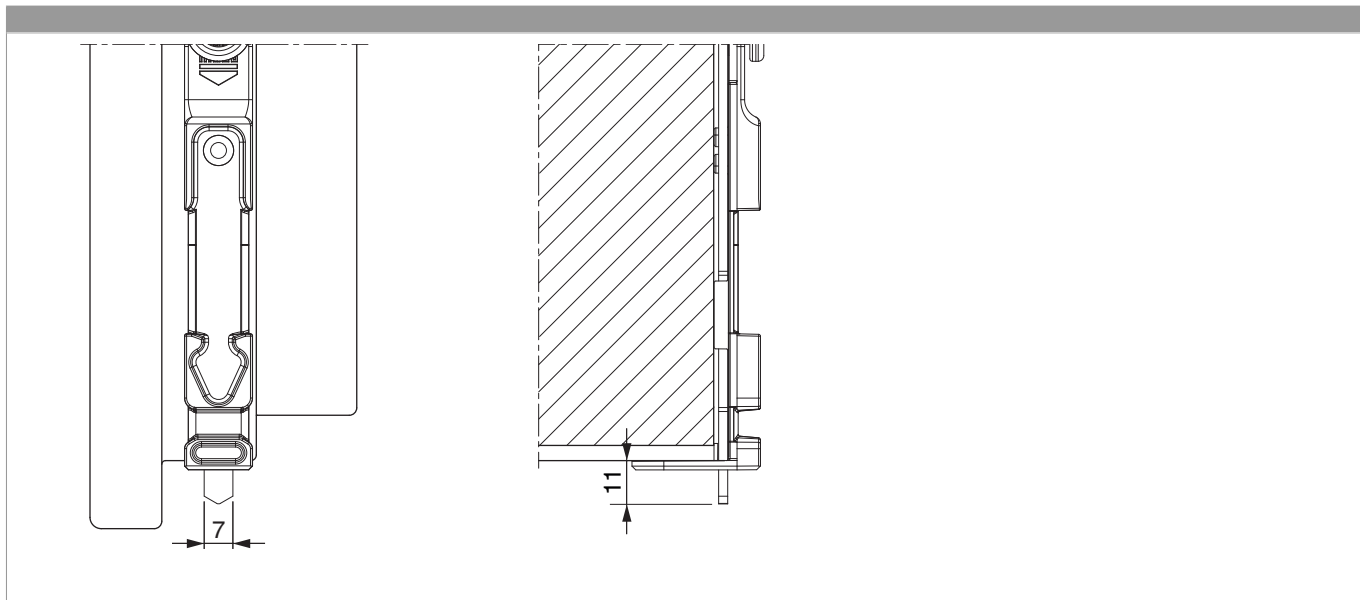

### Posizionare/confrontare i riferimenti

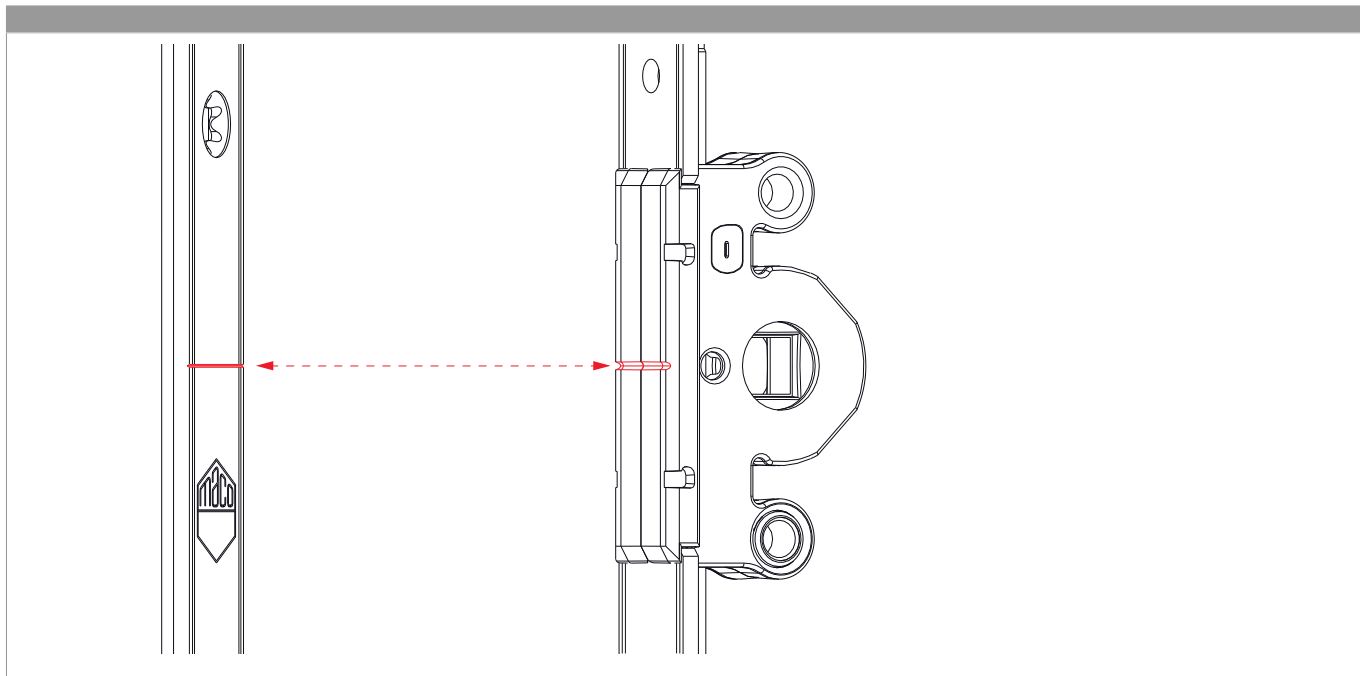



## Regolazione pressione

