

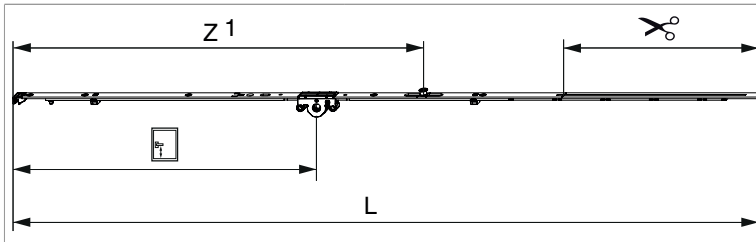

201835 - Cremonese A-B Multi Matic 1340 E15 fix con 1 fungo HBB 1.091-1.340 HM500 argento

Disegni tecnici



						L		N°
argento	1340	15	500	1.091 - 1.340	260,5	1.236,5	10	201835

Tabella posizionamento viti

N°		1	2	3	4	5	6	7	8	9	10	11	12	13	14
201835	6	18,5	91,5	328,5	574	685	868,5								

Tabella punti di chiusura

N°		Z1	Z2	Z3	Z4
201835	1	640			

Quote della scatola cremonese

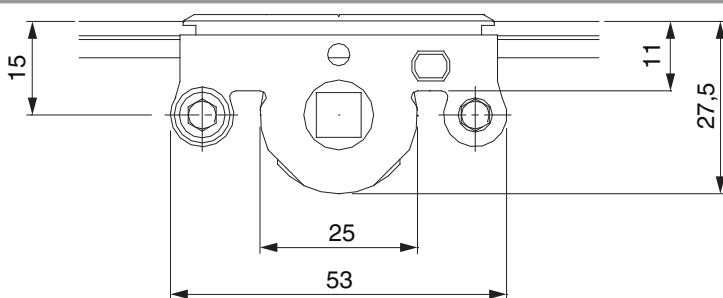

- Larghezza fresata per scatola cremonese 12 mm
- Per fissaggio maniglia utilizzare viti SPAX Ø 5 mm o viti M5.

Schema di foratura

Per serramenti in legno

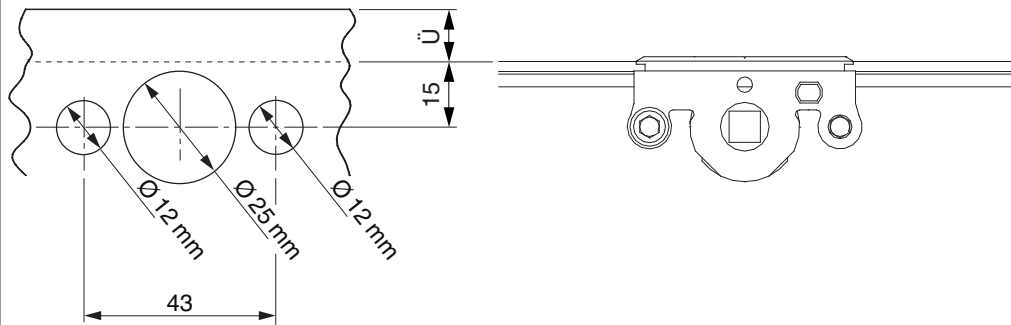

Per serramenti in PVC e alluminio

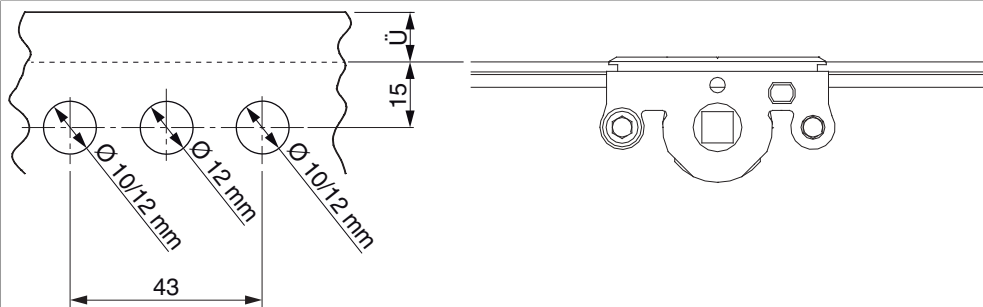

Schema di tranciatura

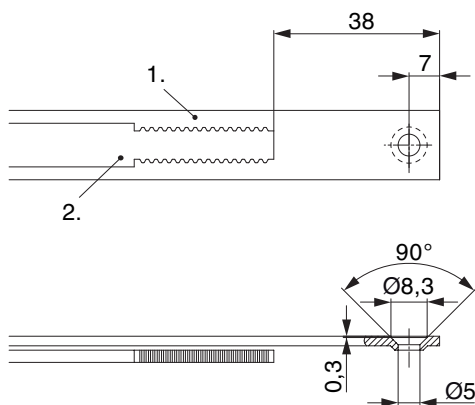

• Consigliamo di trattare il taglio dei componenti TRICOAT-PLUS con la vernice di ritocco TRICOAT-PLUS (cod. 358440).

1. Frontale
2. Asta mobile

Collegamento a clips

Agganciare collegamenta a clips

①

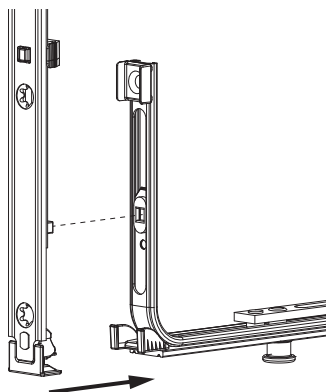

②

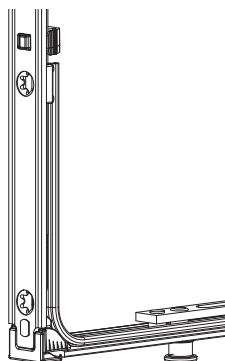

Sganciare collegamento clips

①

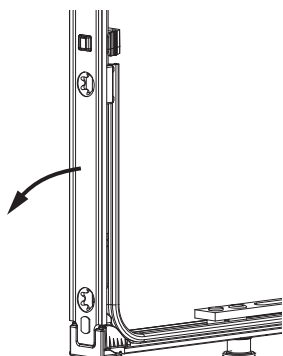

②

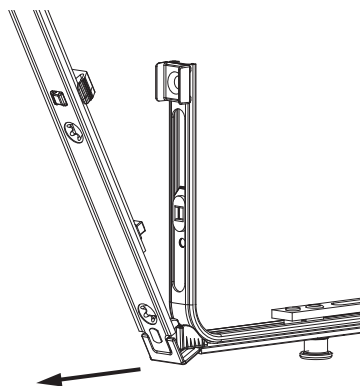

③

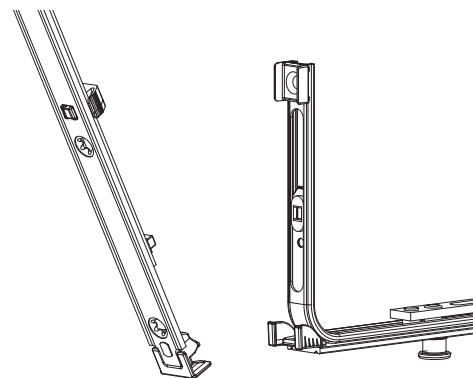

Collegamento scarpetta dentata

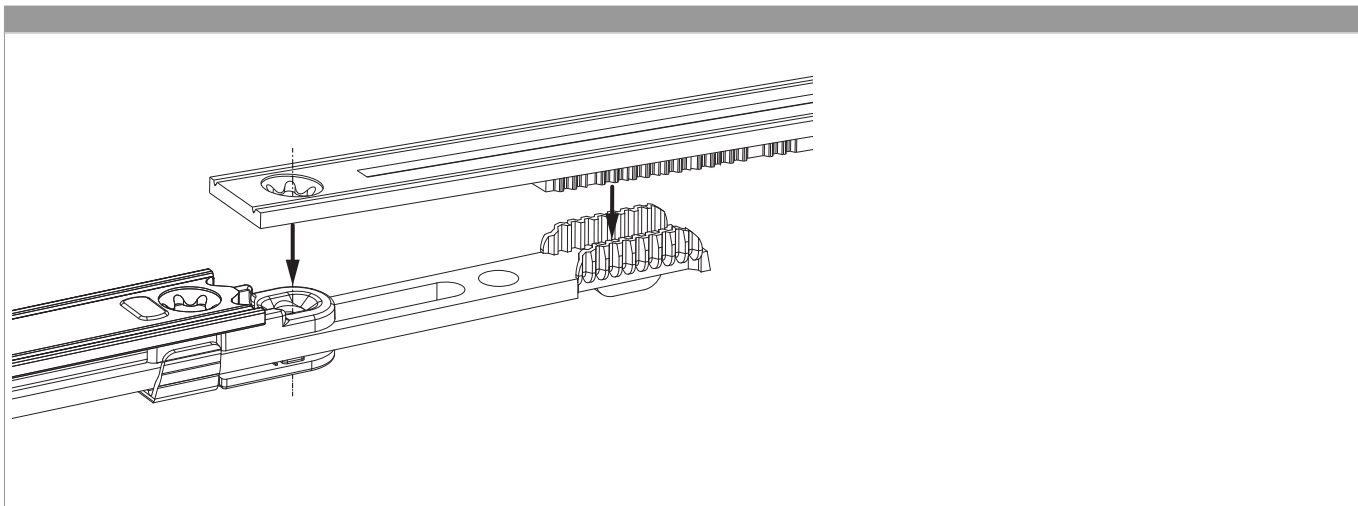

Regolazione pressione

Fungo e nottolino

