



WEEN

BRACCIO SUPPLEMENTARE PER ANTA RIBALTA



Braccio supplementare per anta ribalta | Tilt and turn additional arm
Bras supplémentaire oscillo-battant | Compás suplementario oscilobatiante



Leve, viti e grani in acciaio inox, corpo in zama.



Levers, screw and setscrews in stainless steel, zamak body.



Leviers, vis et grains en acier inox, corps en zamak.



Levas, tornillos y prisioneros de acero inox, cuerpo de zamac.

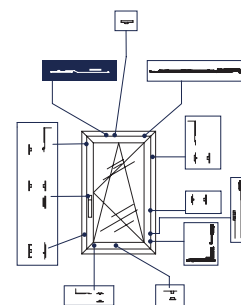

ART.	3520.30				3550L.30			
Imballo Package Conditionnement Embalaje	5 Pz				5 Pz			
Finiture disponibili Available finishes Finitions disponibles Acabados disponibles	1	2	3	4	1	2	3	4

LARGHEZZA L > 1200

WEIGHT L > 1200

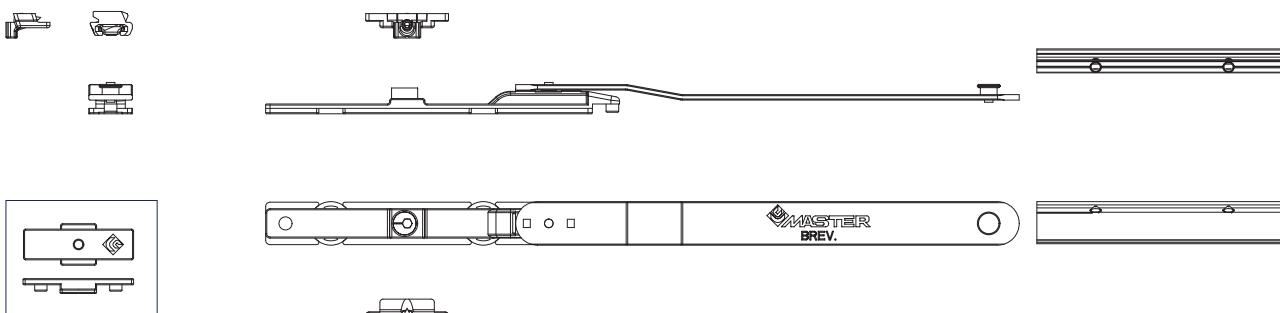

In aggiunta nella versione LOGICA
Additional in LOGIC version

ANTA RIBALTA TILT AND TURN			
	DESCRIZIONE DESCRIPTION	ART.	NODO SECTION
WEEN	L anta da 1200mm a 1700mm L sash from 1200mm to 1700mm	3520.30	A01 - A02 - A05 - A06
		3400G.30	A03 - A04 - A07

LOGICA TILT BEFORETURN			
	DESCRIZIONE DESCRIPTION	ART.	NODO SECTION
WEEN	L anta da 1200mm a 1700mm L sash from 1200mm to 1700mm	3550L.30	A01 - A02 - A05 - A06
		3400LG.30	A03-A04 - A07

REGOLAZIONI | ADJUSTEMENT

3520.30

FORATURA ASTINE
MACHINING OF THE RODS (HOLES)

ANTA
SASH

Art. 3520.22 - A/R 2.0
Art. 3400.22 - A/R WEEN

L-638 A/R - 3550A/3520
L-692 A/R - WEEN - 3420X

TELAIO
FRAME

