

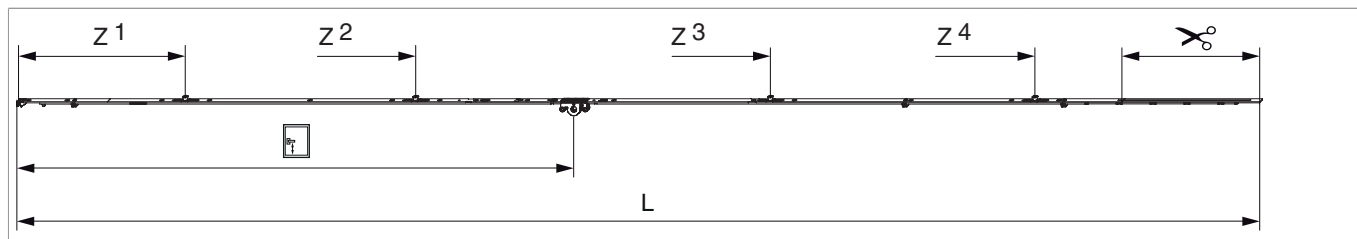

201839 - Cremonese A-B Multi Matic 2450 E15 fix con 4 funghi HBB 2.201-2.450 HM1.050 argento

Disegni tecnici



		L						Nº
argento	2450	2.346,5	15	1.050	2.201 - 2.450	260,5	10	201839

Tabella posizionamento viti

Nº		1	2	3	4	5	6	7	8	9	10	11	12	13	14
201839	14	18,5	91,5	270	360	550	705	795	863,5	1.124	1.388	1.465	1.685	1.875	1.965

Tabella punti di chiusura

Nº		Z1	Z2	Z3	Z4
201839	4	315	750	1.420	1.920

Dime

			Nº
Dima forature per fori martellina MM	per punta 3 mm	1	203861
Dima forature per fori martellina MM	per punta D=3 mm e D=12 mm	1	203862



201839 - Cremonese A-B Multi Matic 2450 E15 fix con 4 funghi HBB 2.201-2.450 HM1.050 argento

Quote della scatola cremonese

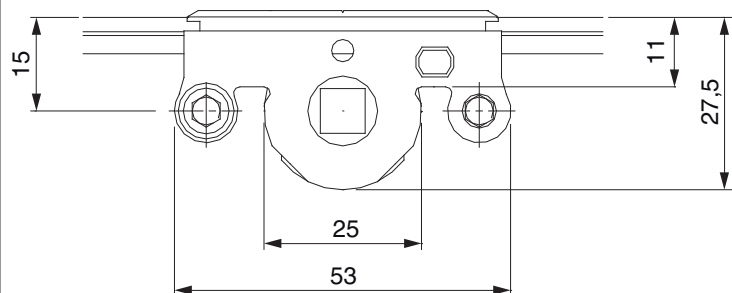

- Larghezza fresata per scatola cremonese 12 mm
- Per fissaggio maniglia utilizzare viti SPAX Ø 5 mm o viti M5.

Schema di fresata

per PVC e alluminio

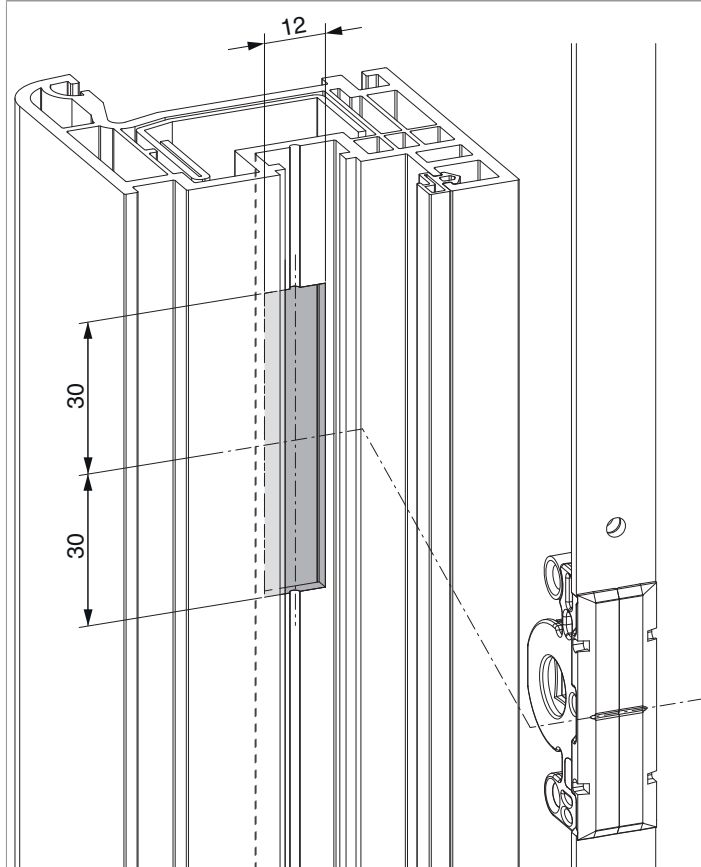



201839 - Cremonese A-B Multi Matic 2450 E15 fix con 4 funghi HBB 2.201-2.450 HM1.050 argento

Schema di foratura

Per serramenti in legno

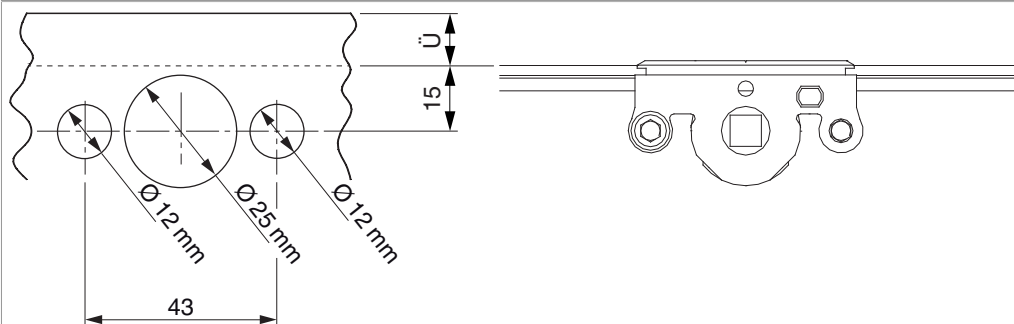

Per serramenti in PVC e alluminio

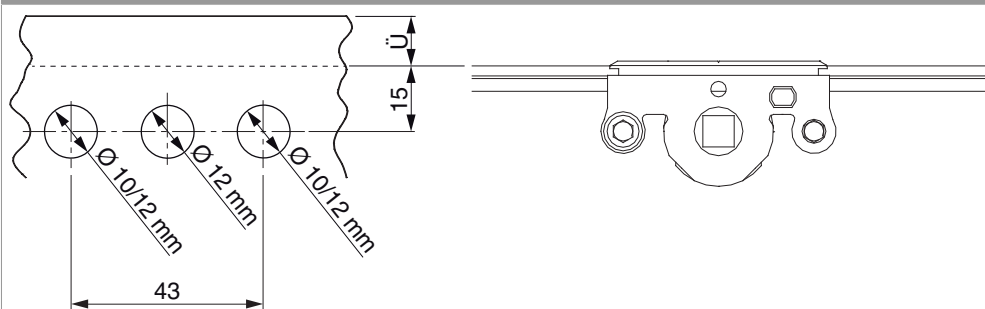

Schema di tranciatura

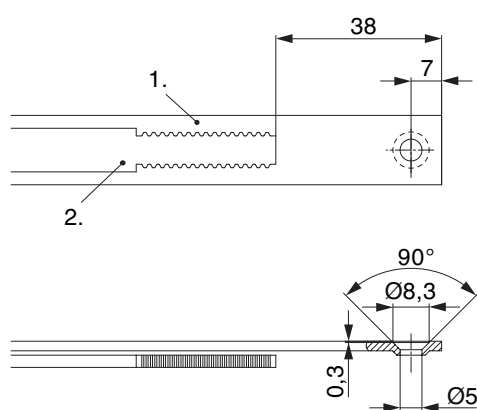

• Consigliamo di trattare il taglio dei componenti Tricoat-Evo con la vernice di ritocco Tricoat-Evo (cod. 373439).

1. Frontale
2. Asta mobile



201839 - Cremonese A-B Multi Matic 2450 E15 fix con 4
funghi HBB 2.201-2.450 HM1.050 argento

Collegamento a clips

Agganciare collegamenta a clips

①

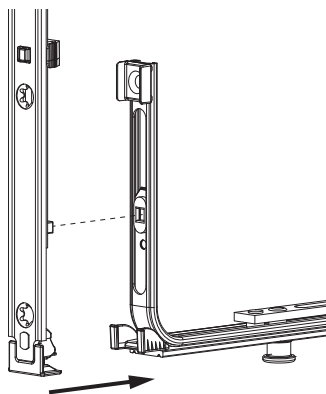

②

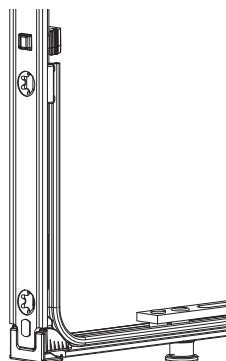

Sganciare collegamento clips

①

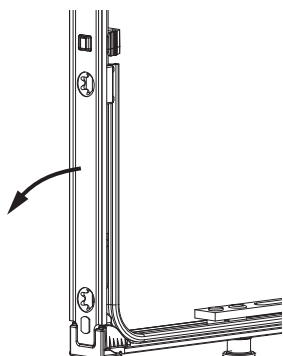

②

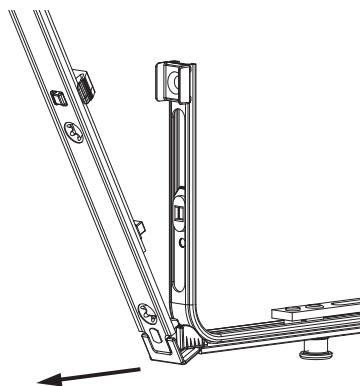

③

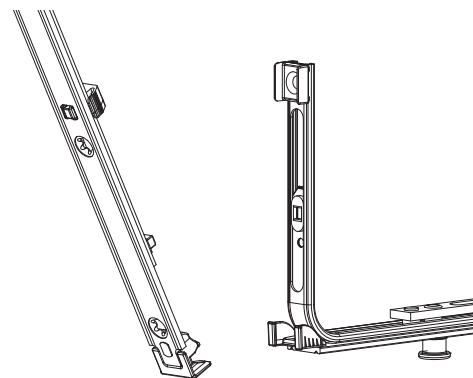



201839 - Cremonese A-B Multi Matic 2450 E15 fix con 4 funghi HBB 2.201-2.450 HM1.050 argento

Collegamento scarpetta dentata

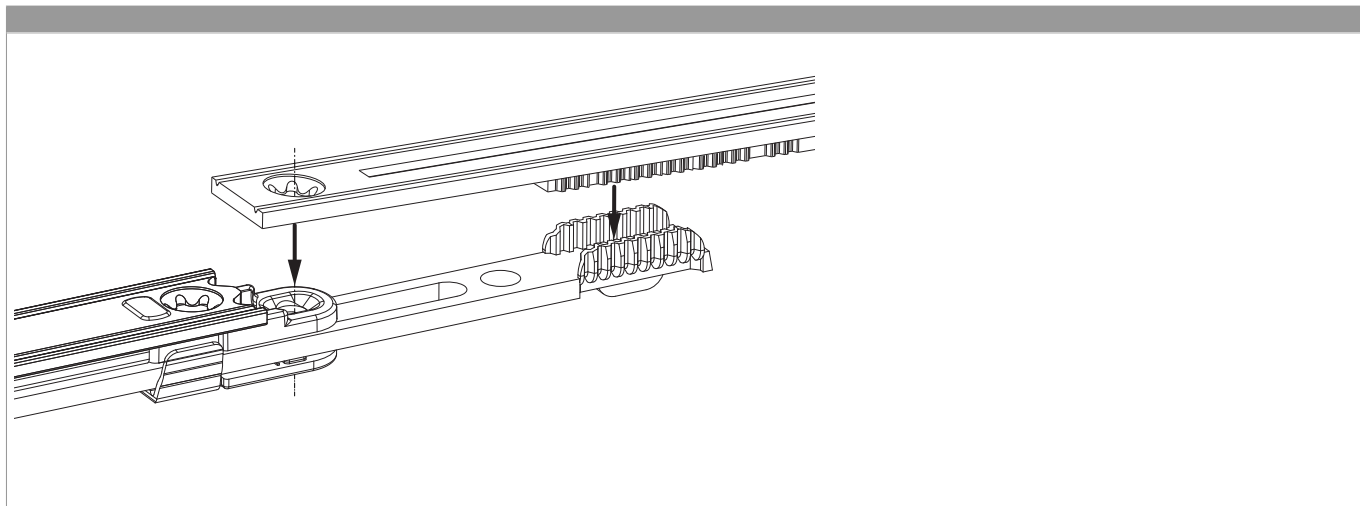

Regolazione pressione

