

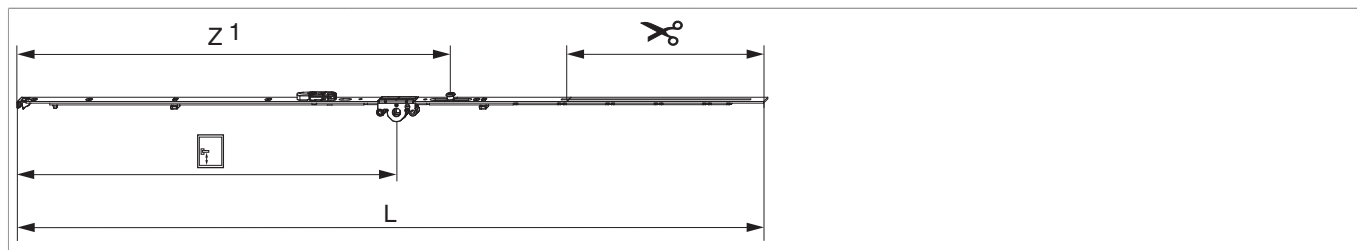

209770 - Cremonese Multi Matic 1090 E15 fix con 1 fungo HBB 841-1.090 HM500 argento

Disegni tecnici



		L							Nº
argento	1090	986,5	15	500	841 - 1.090	260,5	1	20	209770

Tabella posizionamento viti

Nº		1	2	3	4	5	6	7	8	9
209770	5	18,5	91,5	328,5	604					

Tabella punti di chiusura

Nº		Z1	Z2
209770	1	570	

Dime

			Nº
Dima forature per fori martellina MM	per punta 3mm	1	203861
Dima forature per fori martellina MM	per punta D=3 mm e D=12 mm	1	203862

Quote della scatola cremonese

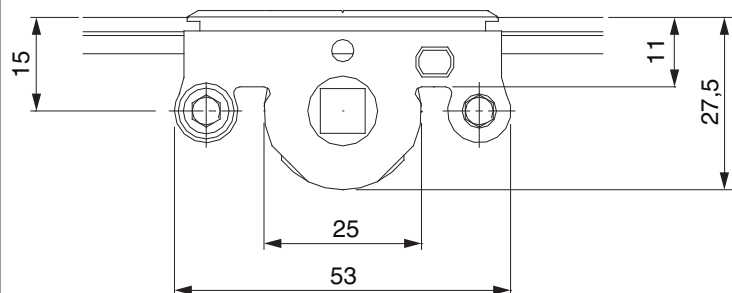

- Larghezza fresata per scatola cremonese 12 mm
- Per fissaggio maniglia utilizzare viti SPAX Ø 5 mm o viti M5.

Schema di fresata

per PVC e alluminio

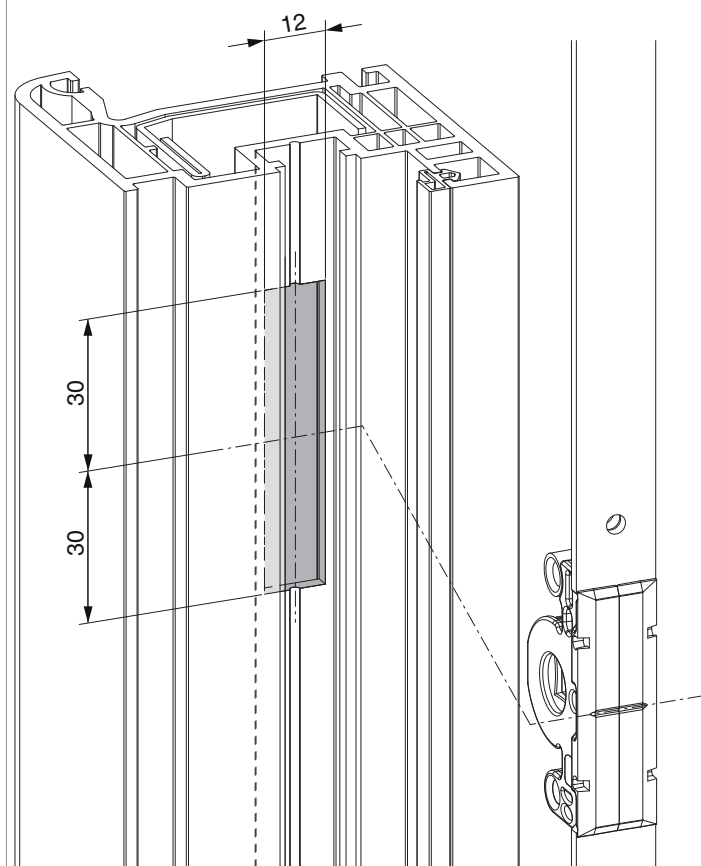

Schema di foratura

Per serramenti in legno

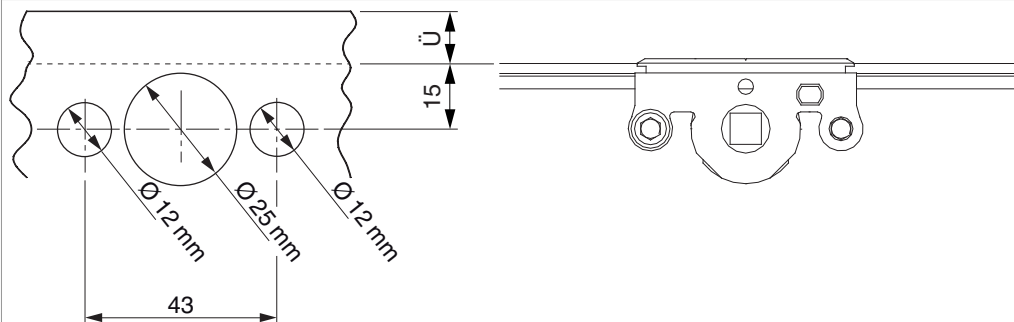

Per serramenti in PVC e alluminio

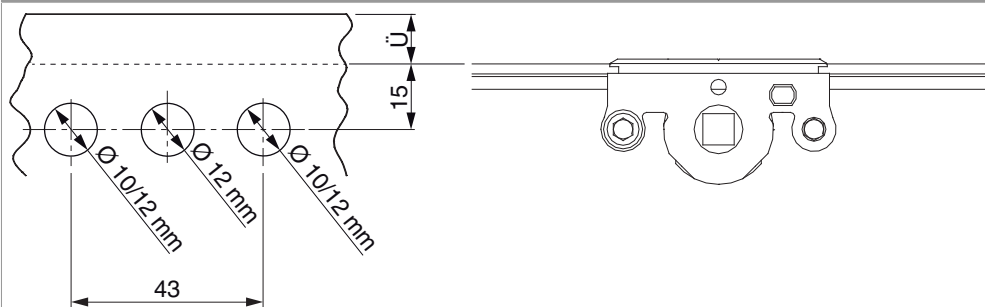

Schema di tranciatura

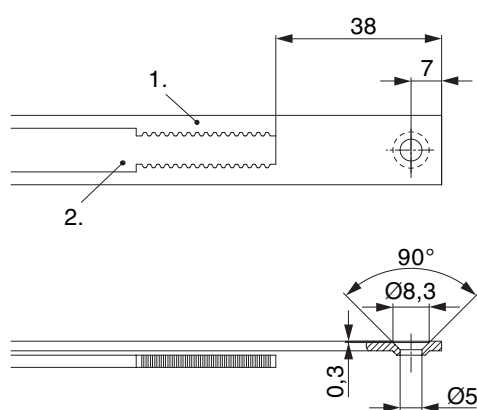

• Consigliamo di trattare il taglio dei componenti TRICOAT-PLUS con la vernice di ritocco TRICOAT-PLUS (cod. 358440).

1. Frontale
2. Asta mobile

Posizionamento scontri alza anta

Scontro alza-anta A4 / senza scrocco porta

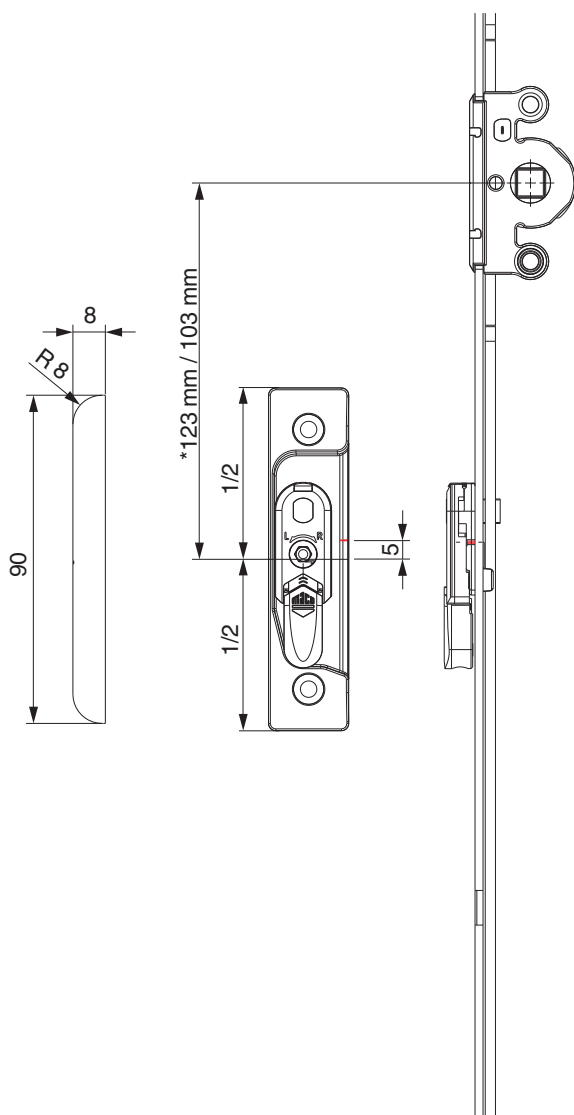

* con cremonesi grandezza 660



A12

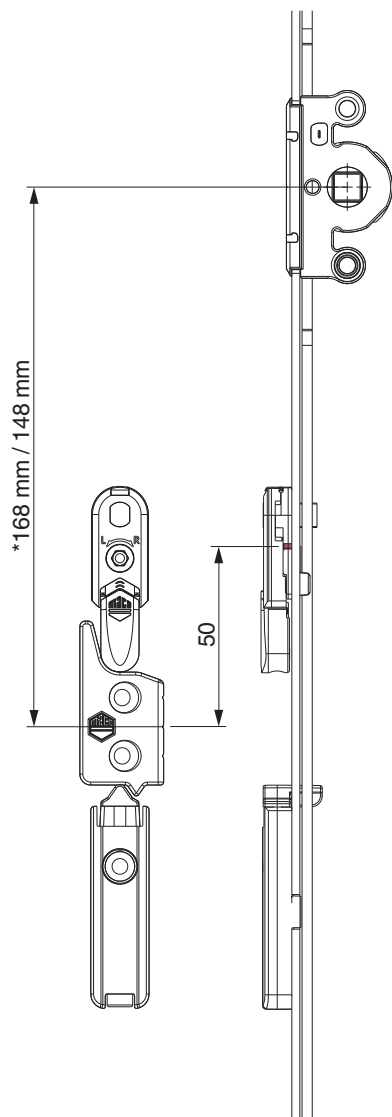

* con cremonesi grandezza 660

Oscillazione e regolazione in altezza dell'alza anta

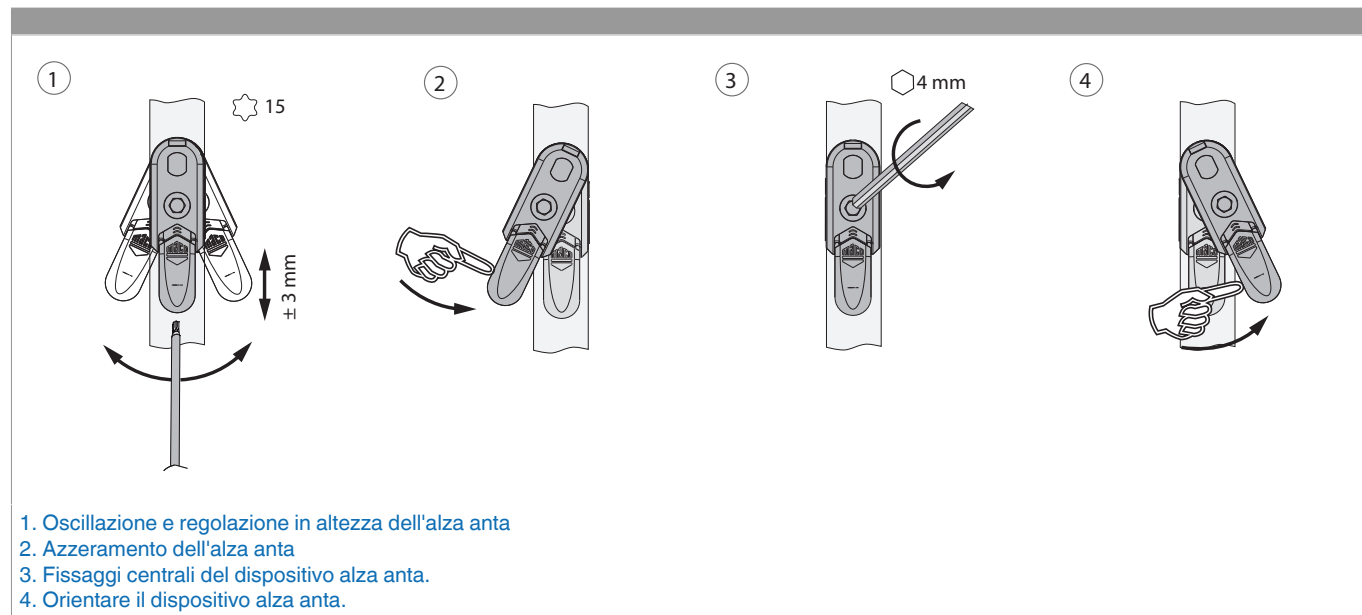

Collegamento a clips

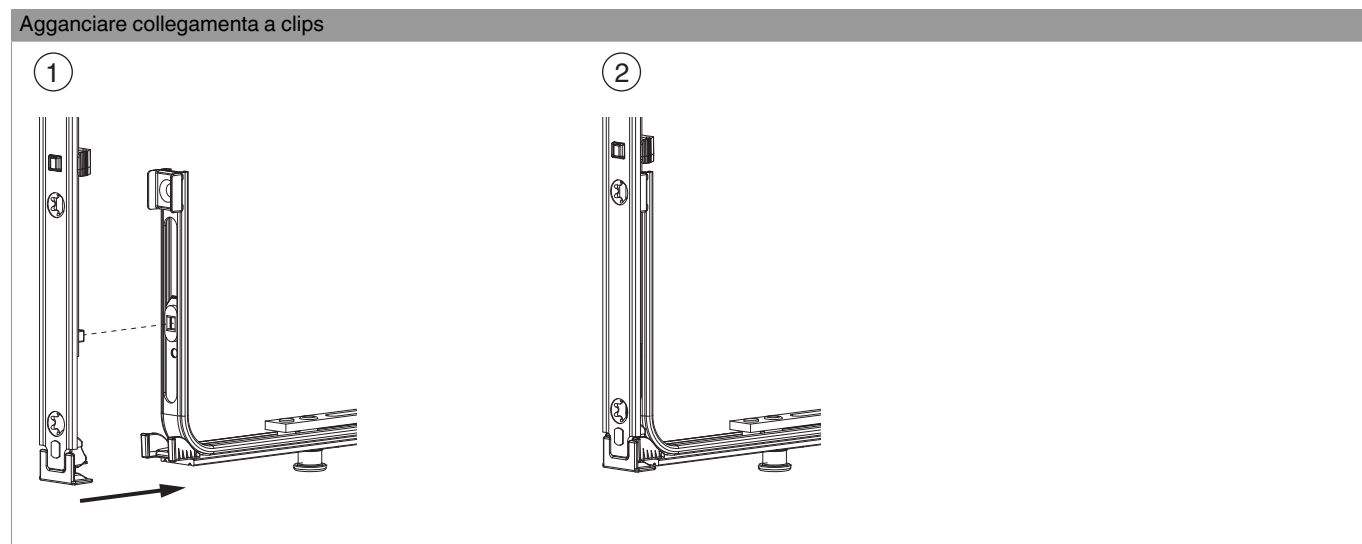

Sganciare collegamento clips

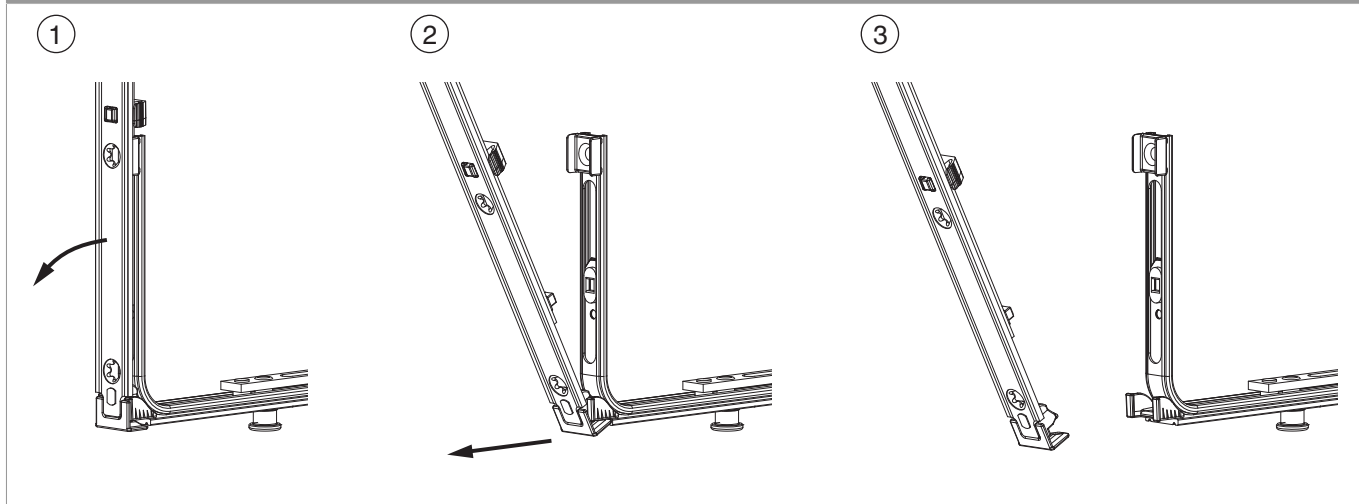

Collegamento scarpetta dentata

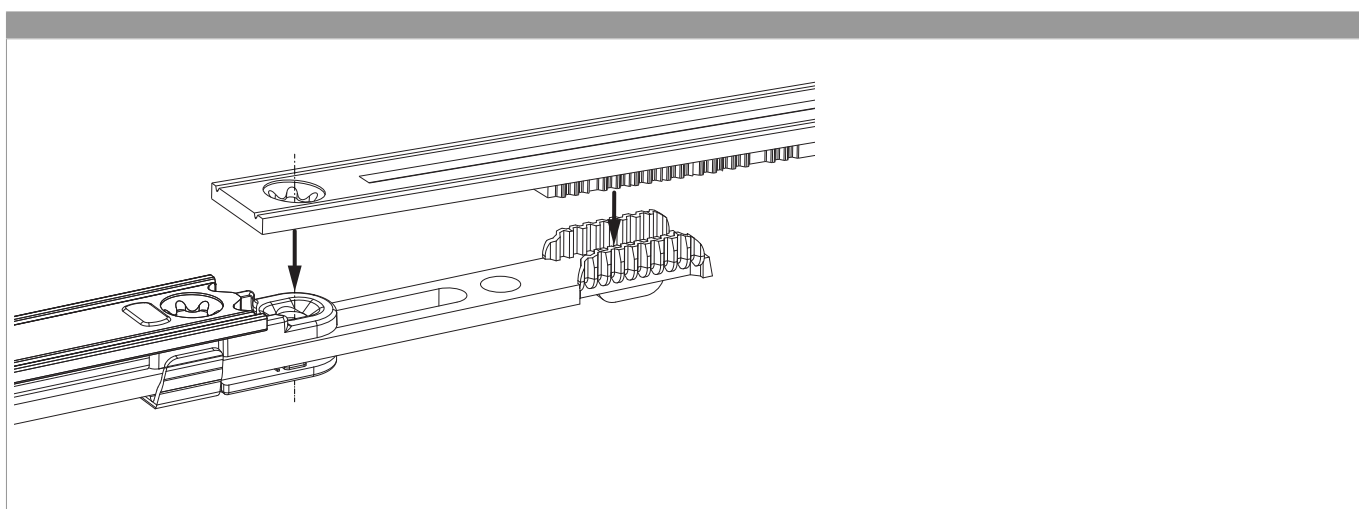

Regolazione pressione

Fungo e nottolino

