

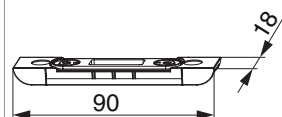

55112 - Scontro catenaccio A4 scost.9 mm 1 foro argento

Disegni tecnici



			L	B	H		Nº
argento	A4 scost.9 mm	1 foro	90	18	8	100	55112 ^{1) 2)}

¹⁾ Profondità fresata 18 mm

²⁾ Lunghezza fresata 90 mm

Dime

					Nº
Dima fresa per chiusura centrale inferiore MM-bilanciere	2 ante	Aria 4	801 - 1.500	1	214164

Sezioni profilo

A4 scost.9 - 1 anta

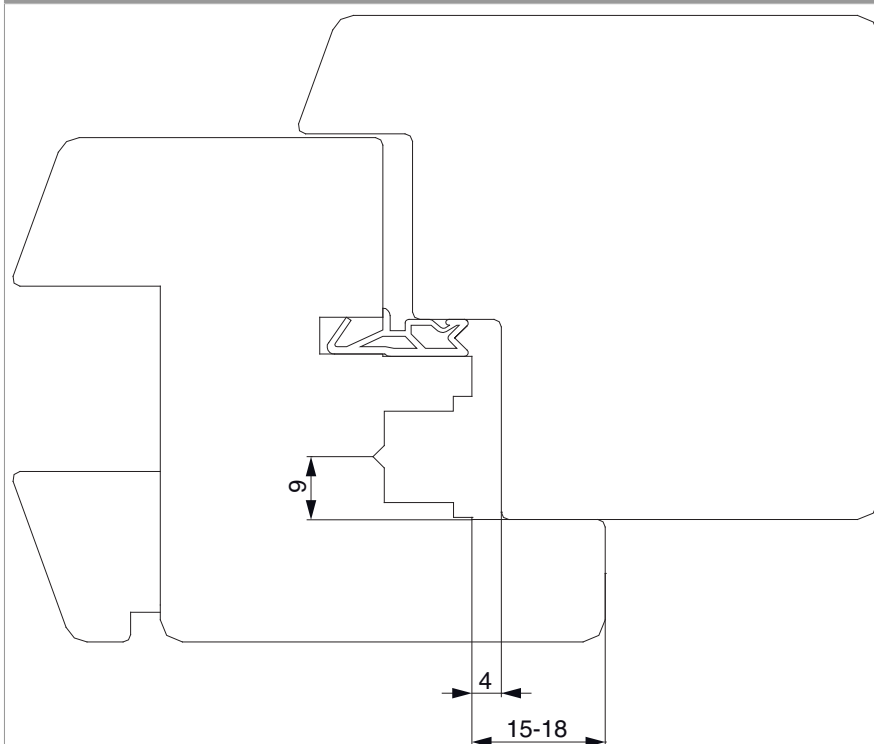

A4 scost.9 - 2 ante

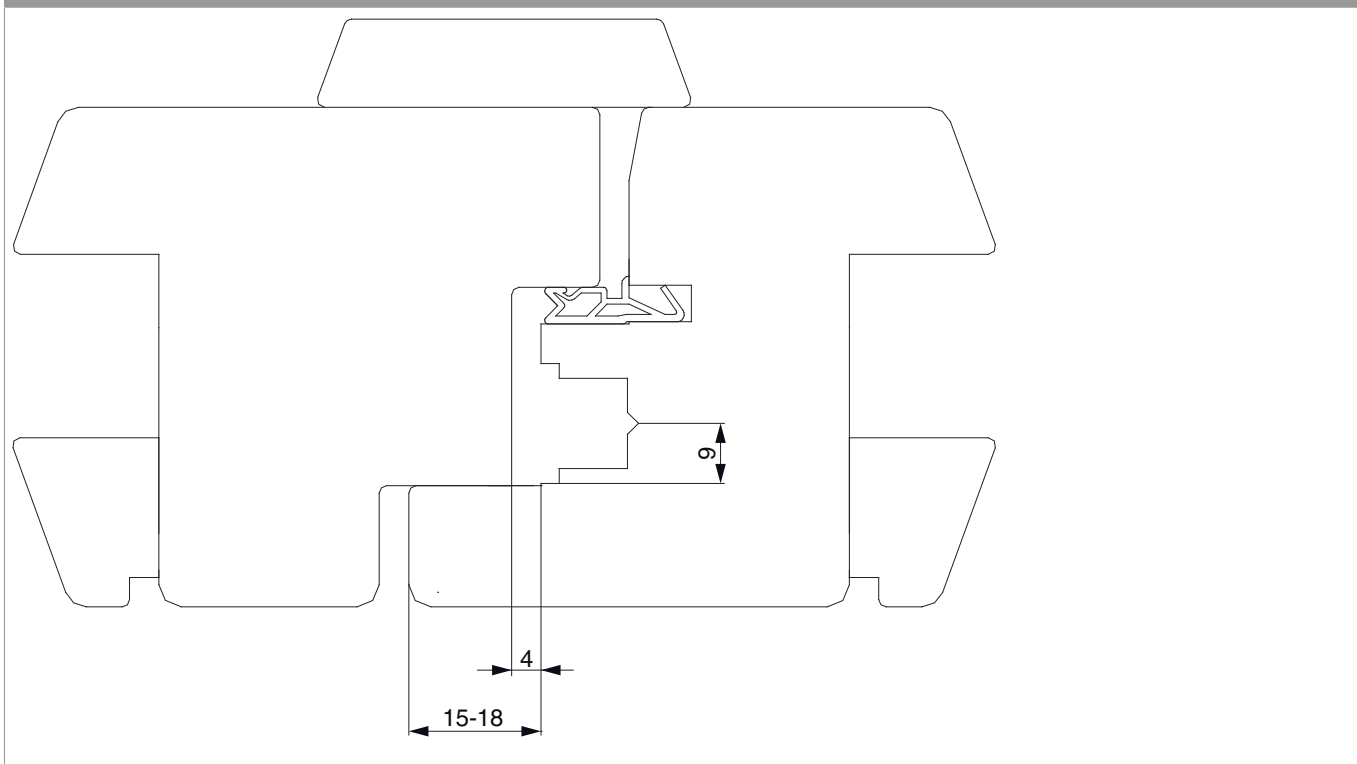

Posizionamento degli scontri

Finestra a 2 ante con 1 catenaccio

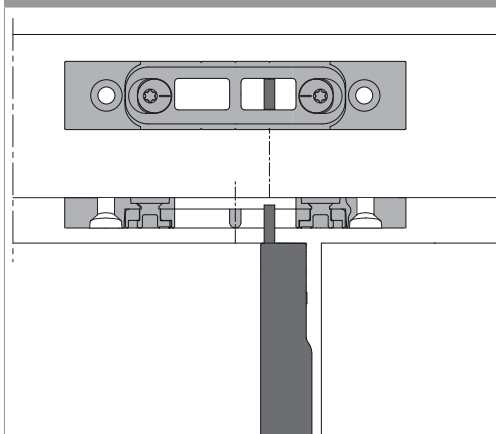

Allineare il centro dell'uscita puntale alla tacca

Finestra a 2 ante con 2 catenacci

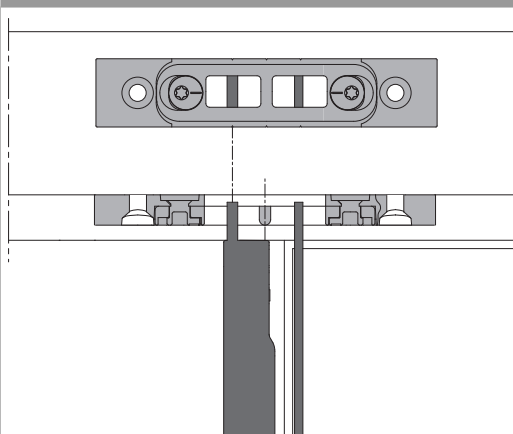

Centro scontro = centro cava ferramenta

Fresata

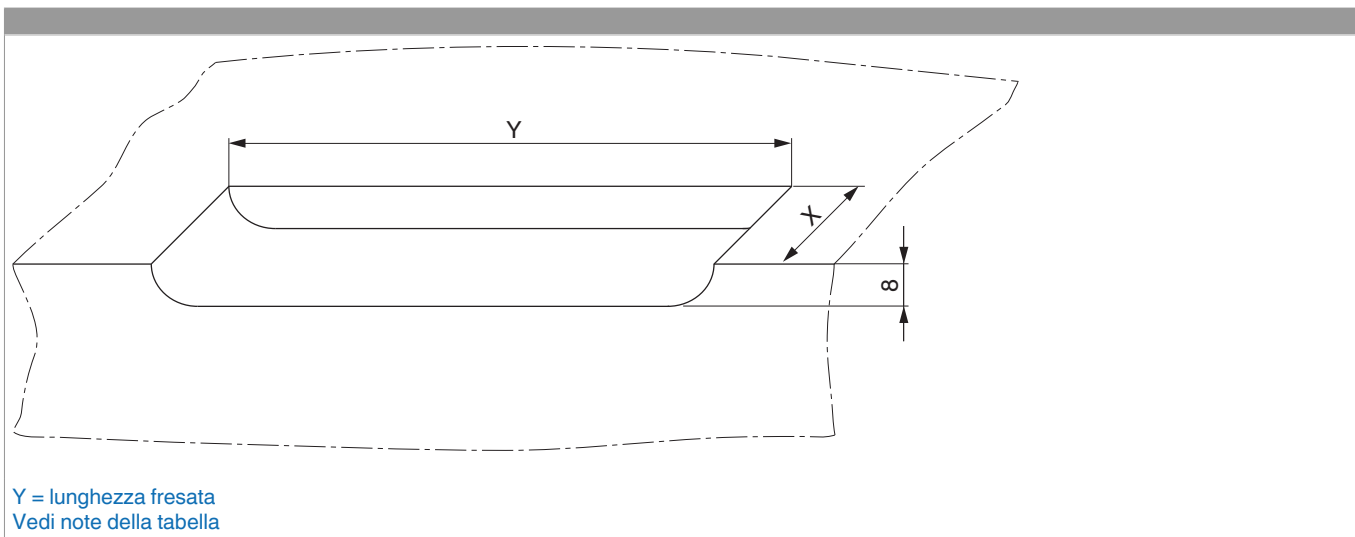

Scostamento	X
scostamento 9 mm	18 mm
scost.13	22 mm

Regolazione pressione

sullo scontro

