

Maniglia di chiusura per ante scorrevoli

Composizione del Kit



Incontro

1 anta : 2 incontri
2 ante : 2 incontri



Maniglia

1 anta : 1 braccio
2 ante : 2 bracci



Incontro

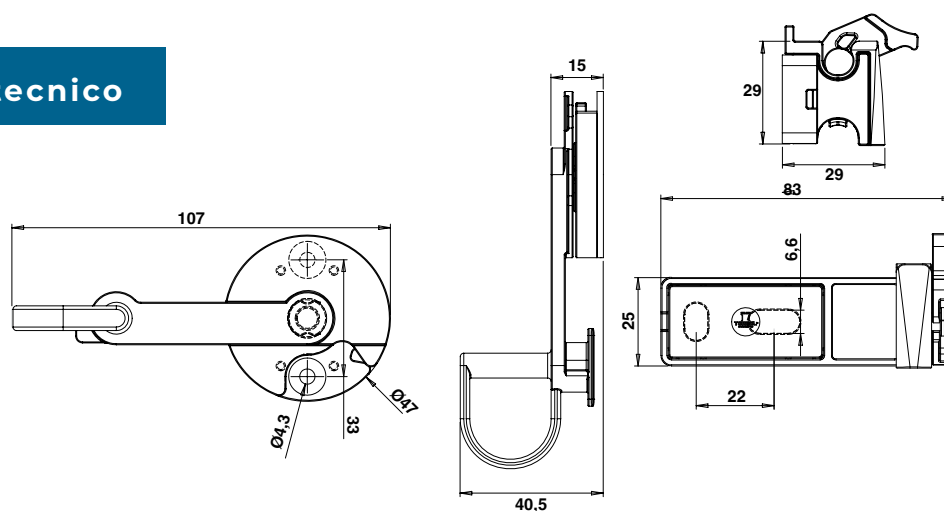

1 anta : 2 incontri
2 ante : 2 incontri

Piano tecnico





Referenze

Maniglia 1A 1 braccio + 2 incontri

Cod.		
B0256010	GREZZO	1
B0256001		1

Maniglia 2A 2 bracci + 2 incontri

Cod.		
B0256020	GREZZO	1
B0256002		1

Le componenti plastiche sono sempre nere.

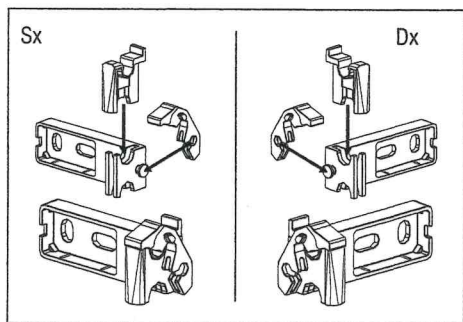
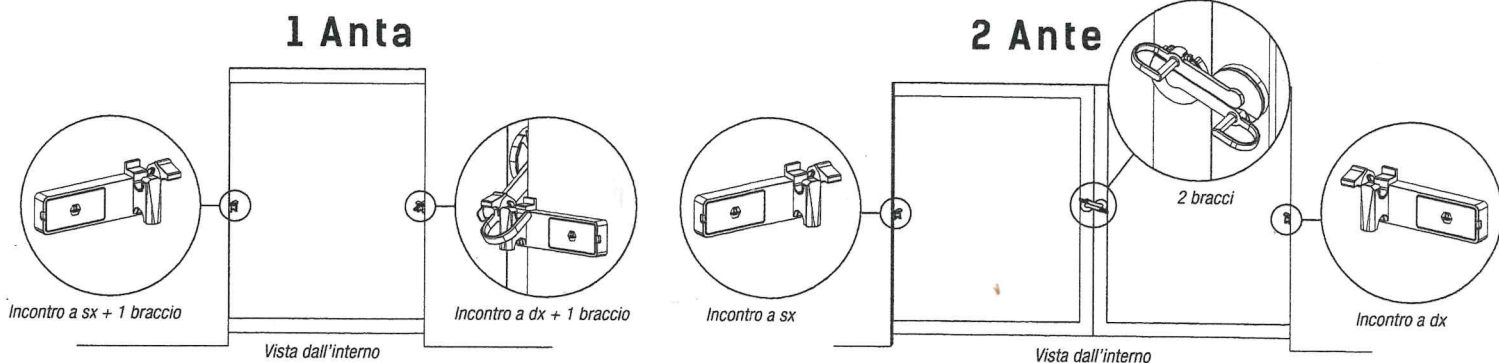

1. Assemblare le componenti plastiche sugli incontri dx/sx.

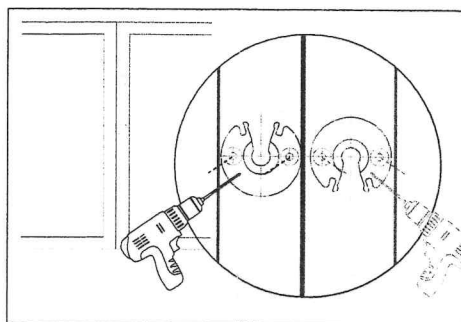

2. Forare i profili delle ante utilizzando la dima qui sotto. Rispettare il verso dei supporti (alto/basso) ed il loro allineamento.

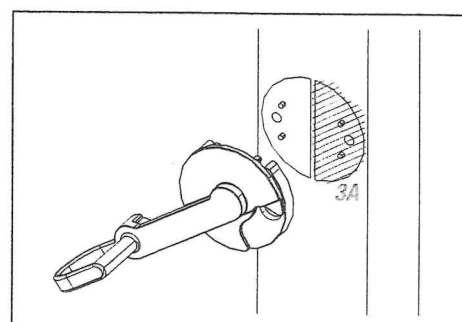

3. Inserire lo/gli spessore/i sotto i bracci.
3A. In caso di necessità tagliare lo spessore e utilizzare solo la metà necessaria.

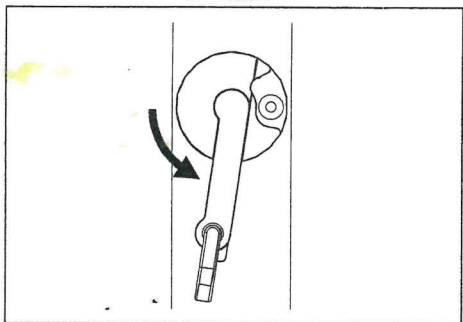

4. Posizionare il braccio sull'anta, rispettare l'orientamento delle dime e ruotare il braccio per accedere alle viti di fissaggio.

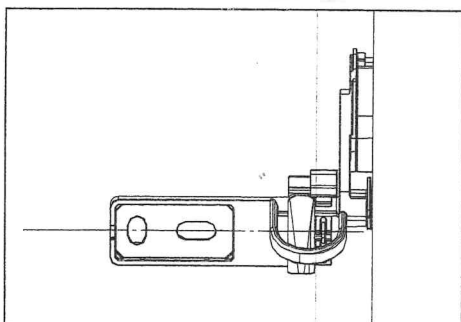

5. Posizionare gli incontri sulla spalletta allineando visivamente centro anello con il centro dell'incontro

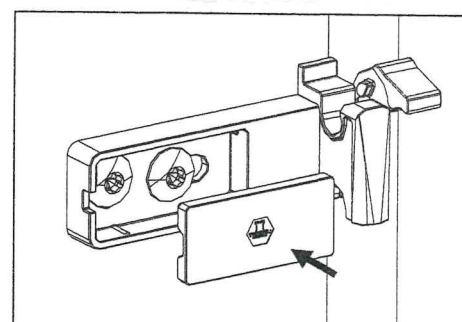

6. Posizionare le mascherine copri-viti.

Dima 1 Anta : **A**

Dima 2 Ante : **A + B**

