

The Drawing and its contents are to be kept secret from third parties, particularly competitors. The drawing and documents which go with it are not to be duplicated either in local or extract, or used in other documentation without express approval (815 and 38 UrHG - §1 and 18 UWG). A reservation of rights in accordance with §12 PatG is declared for the event that a patent is granted.

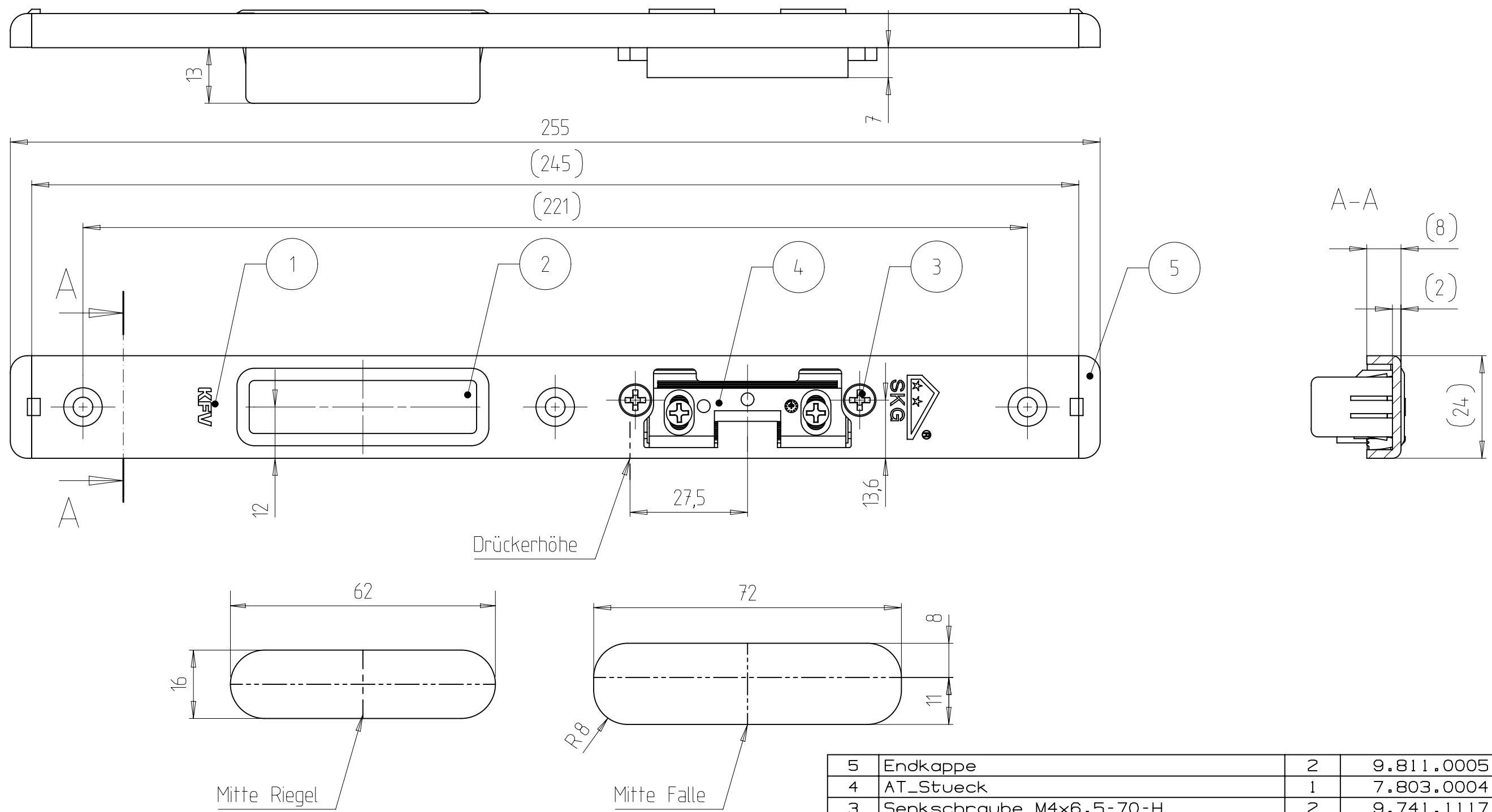

Frästiefe = angegebene Tiefe + min. 1 mm

Fräser  $\varnothing$  16 mm  
 Anlaufring  $\varnothing$  27 mm

gezeichnet DIN links  
 Spiegelbildlich DIN rechts  
 Artikel-Nr. auf der Rückseite geprägt  
 Tolerierung nach ISO 8015  
 Pos. 2 in Pos. 1 geklipst  
 Pos. 1 und 4 und Pos. 3 verschraubt  
 Pos. 5 in Pos. 1 geklipst

Pos	Benennung	Stck	PDM-Nr.	Bemerk
5	Endkappe	2	9.811.00051	
4	AT_Stueck	1	7.803.00041	
3	Senkschraube M4x6,5-70-H	2	9.741.11171	
2	Hinterfuetterung	1	9.806.00080	
1	U-Profil-Schliessblech	1	9.861.19790	

Qty.	Type of Modification	ANT	Drawn	Approved	Date	
		Y7999A				
Volume /mm <sup>3</sup>	Weight/g	Material-No.	Item-No.	Tool-No.		
26577	162,599		25-08-24ERH			
		Tolerance	Part-Discription			
		ISO 2768 mK	U-Profil-Schliessblech			
Scale	Additional Notice					
1 : 1						
Drawn	M. Müller-Bachem	<b>KFV</b>	Document No.	Doc. Part No.	Revision	Status
Date	16.01.2017		7.861.19791	000	00	<b>20</b>
Appr.	P. Thode		Replacement for :	Test procedure		Size
Date	17.01.2017		Replaced by :			A3