

201837 - Cremonese A-B Multi Matic 1950 E15 fix con 3 funghi HBB 1.701-1.950 HM1.050 argento

Disegni tecnici

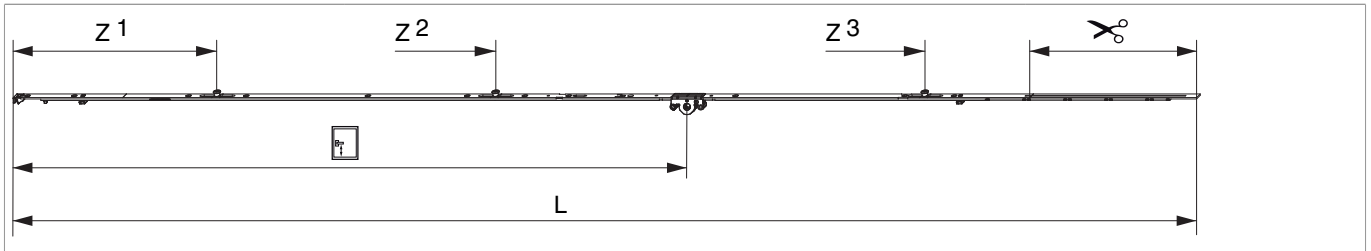

						L		Nº
argento	1950	15	1.050	1.701 - 1.950	260,5	1.846,5	10	201837

Tabella posizionamento viti

Nº		1	2	3	4	5	6	7	8	9	10	11	12	13	14
201837	11	18,5	91,5	270	360	550	705	795	863,5	1.124	1.388	1.465			

Tabella punti di chiusura

Nº		Z1	Z2	Z3	Z4
201837	3	315	750	1.420	

Quote della scatola cremonese

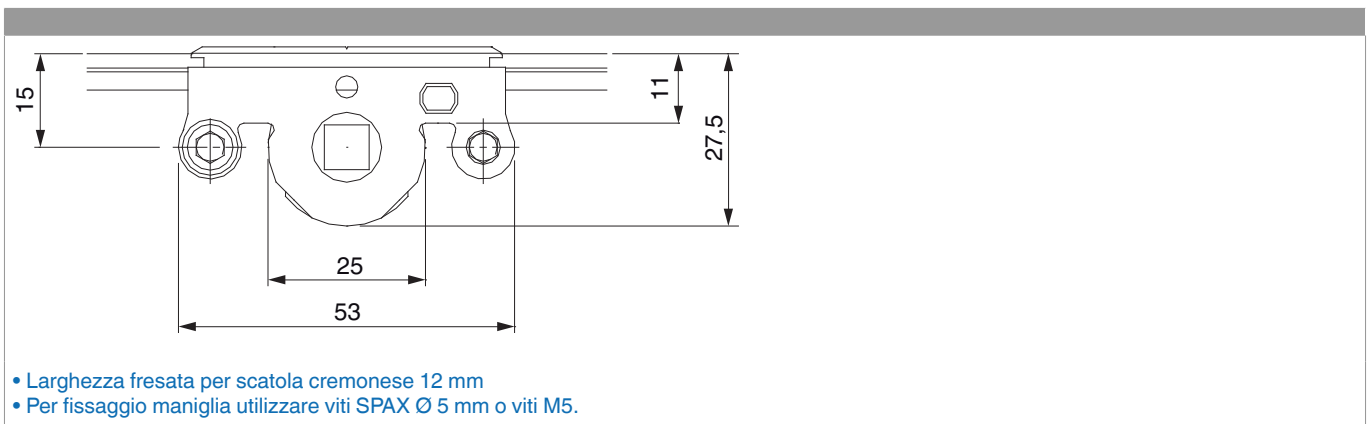

Schema di foratura

Per serramenti in legno

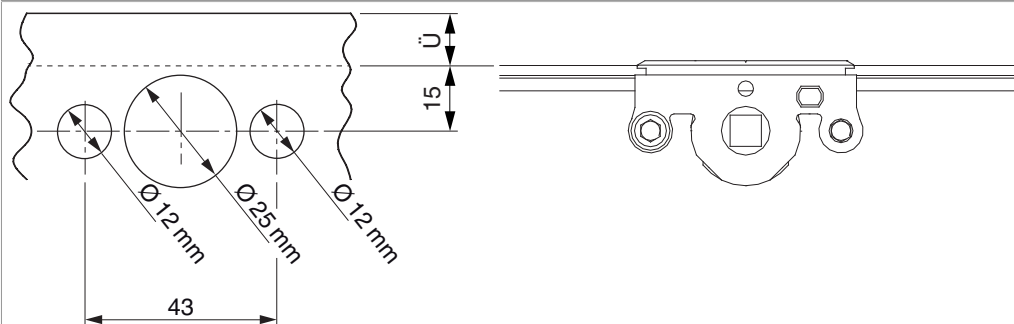

Per serramenti in PVC e alluminio

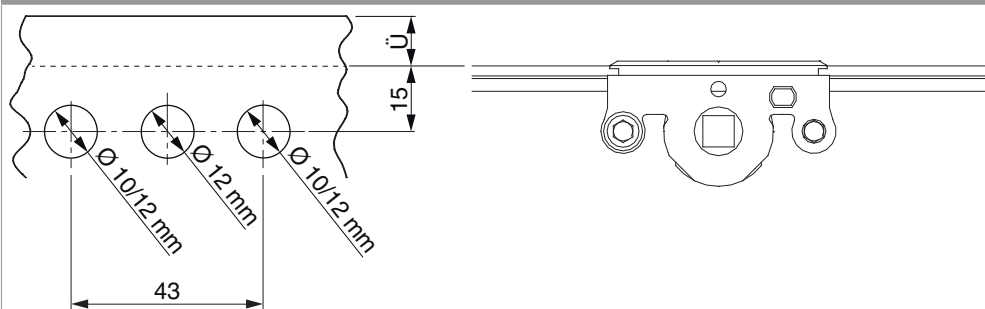

Schema di tranciatura

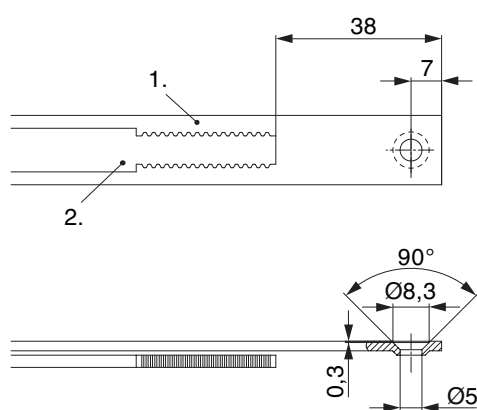

• Consigliamo di trattare il taglio dei componenti TRICOAT-PLUS con la vernice di ritocco TRICOAT-PLUS (cod. 358440).

1. Frontale
2. Asta mobile

Collegamento a clips

Agganciare collegamenta a clips

①

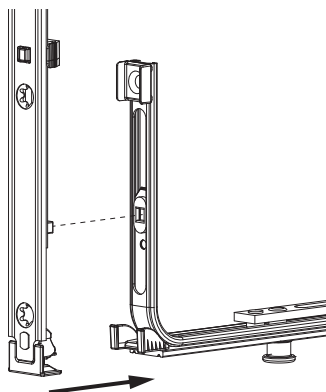

②

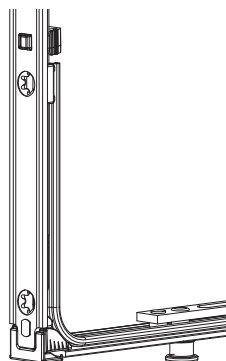

Sganciare collegamento clips

①

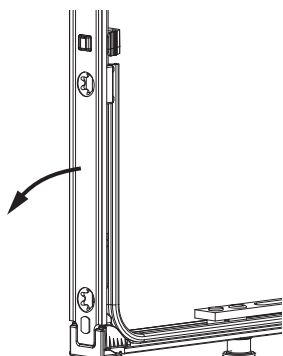

②

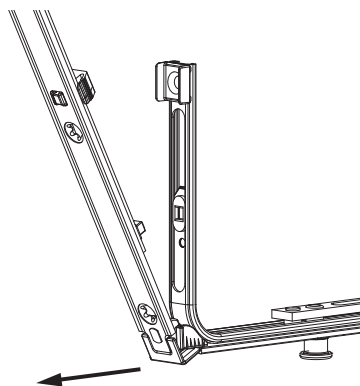

③

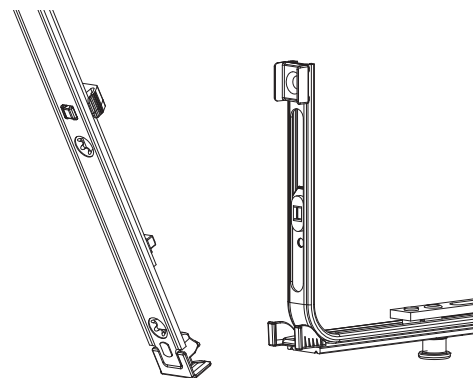

Collegamento scarpetta dentata

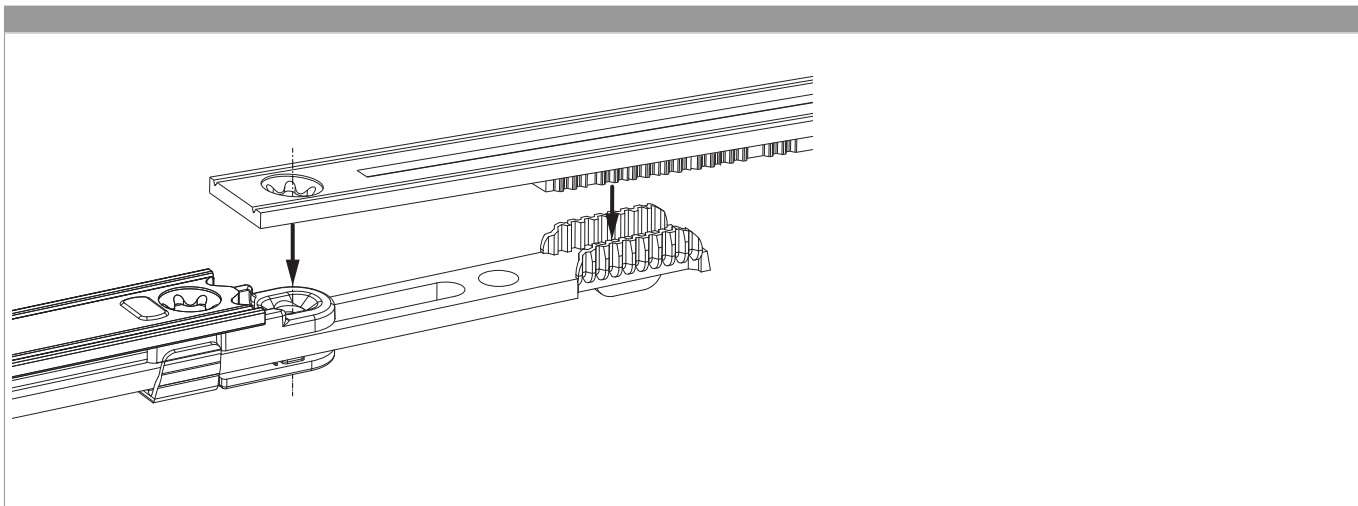

Regolazione pressione

Fungo e nottolino

