

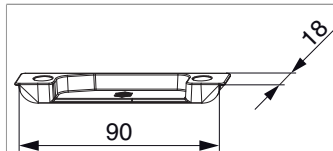

356505 - Scontro alza anta MultiMatic per A4 scost. 9 mm sinistro argento

Disegni tecnici



				L	B	H		Nº
argento	per A4 scost. 9 mm		sinistro	90	18	8	100	356505 ^{1) 2)}

¹⁾ Profondità fresata 18 mm

²⁾ Lunghezza fresata 90 mm

Dime

					Nº
Dima fresa per cremonese fix MM con bilanciante		Aria 4	661 - 1.090	1	214152
Dima fresa per cremonese fix MM con bilanciante		Aria 4	841 - 1.340	1	214153
Dima fresa per cremonese fix MM con bilanciante		Aria 4	1.341 - 1.700	1	214154
Dima fresa per cremonese fix MM con bilanciante		Aria 4	1.701 - 2.200	1	214155
Dima fresa per cremonese fix MM con bilanciante	2 ante	Aria 4	841 - 1.340	1	214157
Dima fresa per cremonese fix MM con bilanciante	2 ante	Aria 4	1.341 - 1.700	1	214158
Dima fresa per cremonese fix MM con bilanciante	2 ante	Aria 4	1.701 - 2.200	1	214159



Sezioni profilo

A4 scost.9 - 1 anta

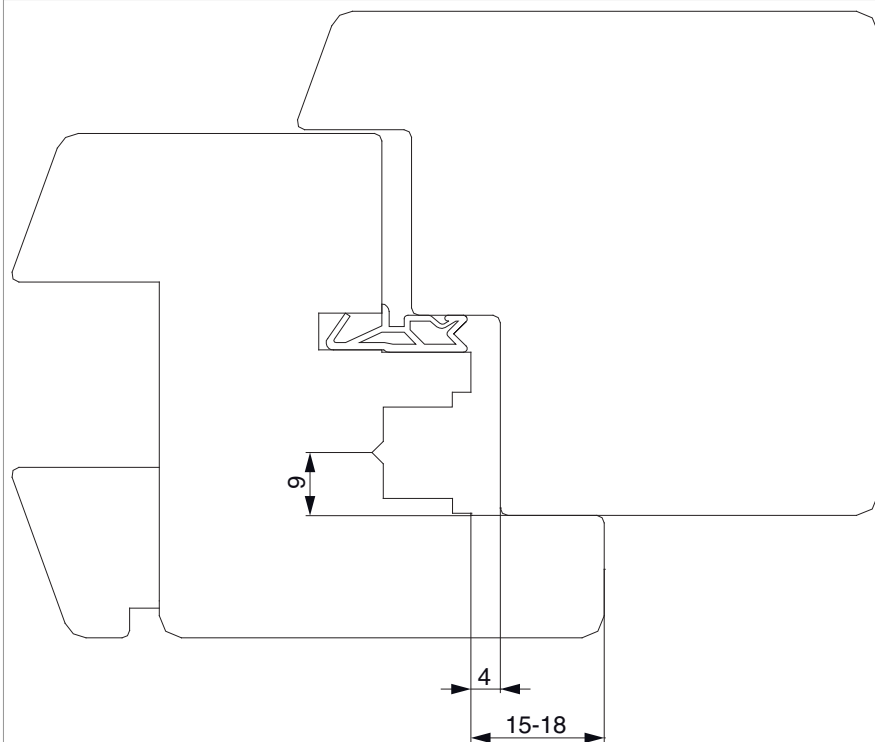

A4 scost.9 - 2 ante

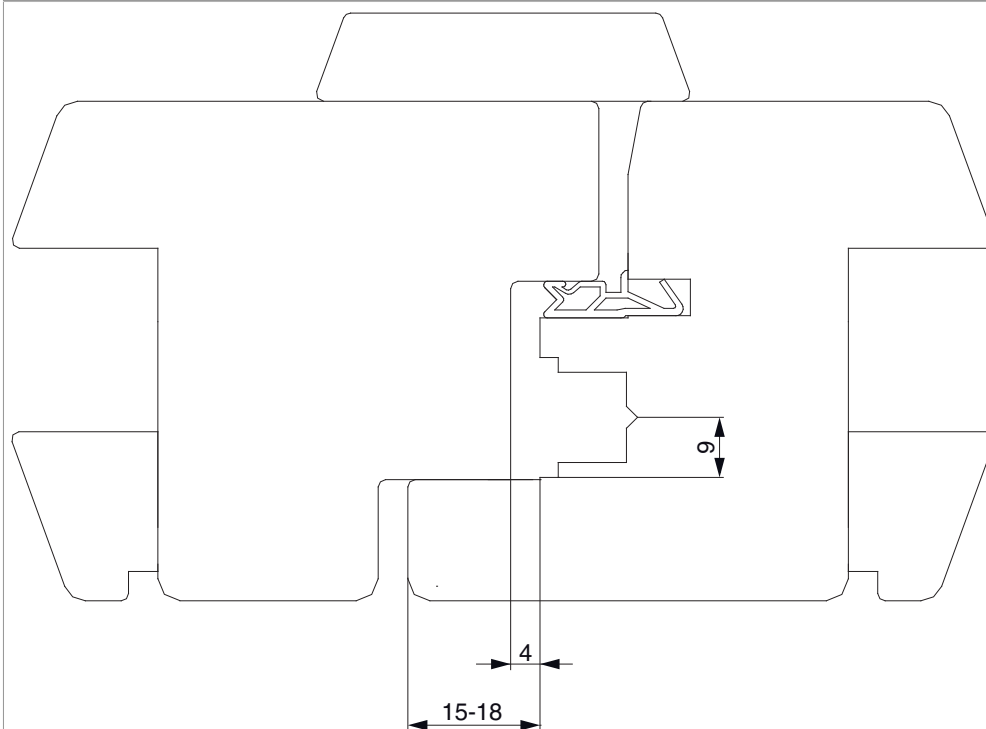

Posizionamento degli scontri

Scontro alza-anta A4 / senza scrocco porta

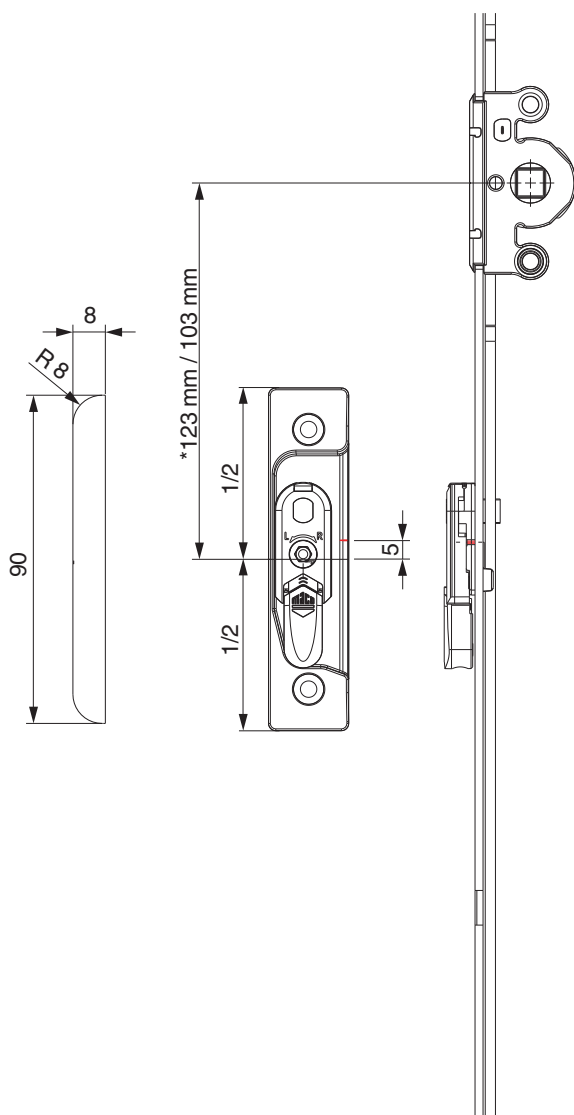

* con cremonesi grandezza 660

Fresata

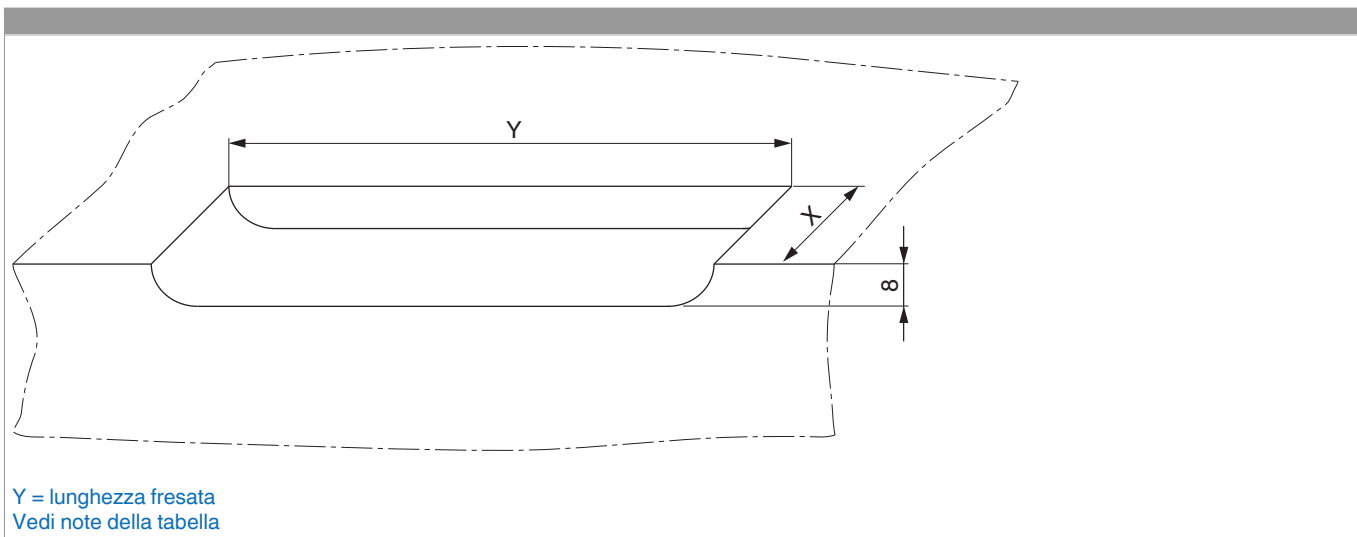

Y = lunghezza fresata
Vedi note della tabella

Scostamento	X
scostamento 9 mm	18 mm
scost.13	22 mm