

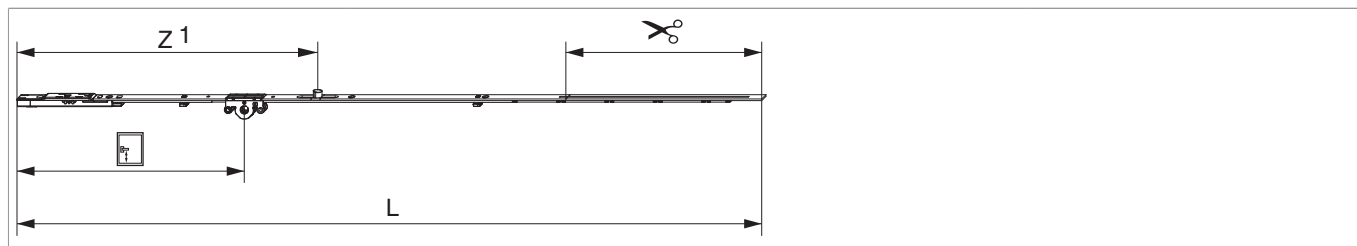

212008 - Cremonese ad inversione Multi Matic 1090 E15 con 1 nottolino HBB 841-1.090 HM300 argento

Disegni tecnici









		L						Nº
argento	1090	985	15	300	841 - 1.090	259	10	212008

Tabella posizionamento viti



Nº		1	2	3	4	5	6	7	8	9	10
212008	5	28	119,5	374	485	617					

Tabella punti di chiusura

Nº		Z1	Z2
212008	1	395	

Dime

			Nº
Dima forature per fori martellina MM	per punta 3mm	1	203861
Dima forature per fori martellina MM	per punta D=3 mm e D=12 mm	1	203862

Quote della scatola cremonese

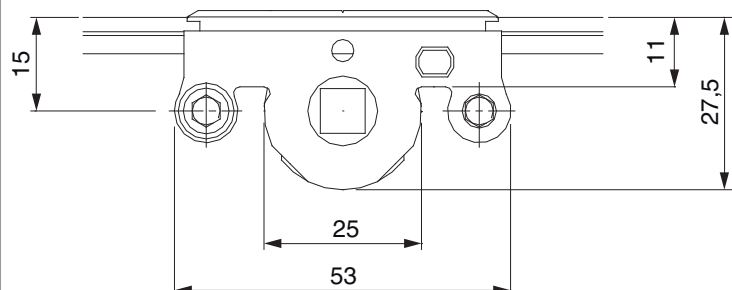

- Larghezza fresata per scatola cremonese 12 mm
- Per fissaggio maniglia utilizzare viti SPAX Ø 5 mm o viti M5.

Schema di foratura

Per serramenti in legno

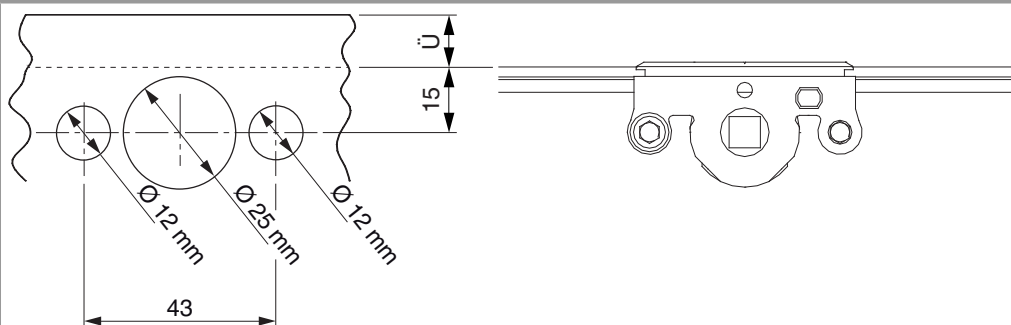

Per serramenti in PVC e alluminio

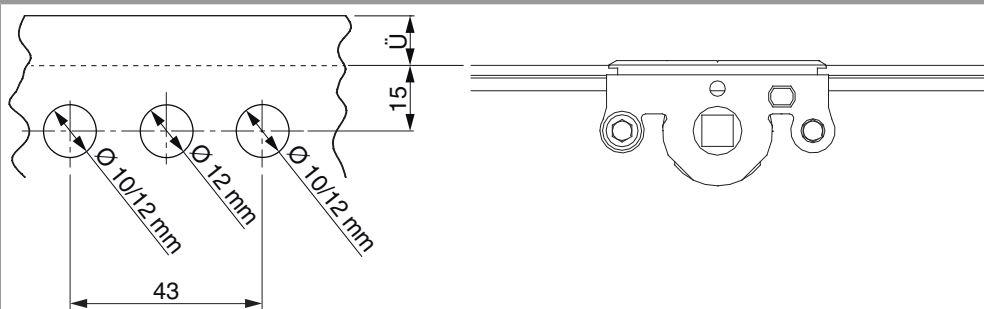

Regolazione uscita puntale (a scelta 11 o 14 mm)

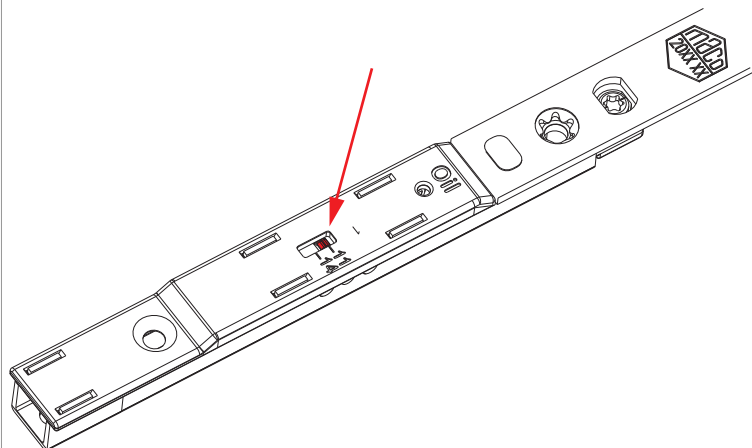

Impostazione di base uscita puntale 11 mm

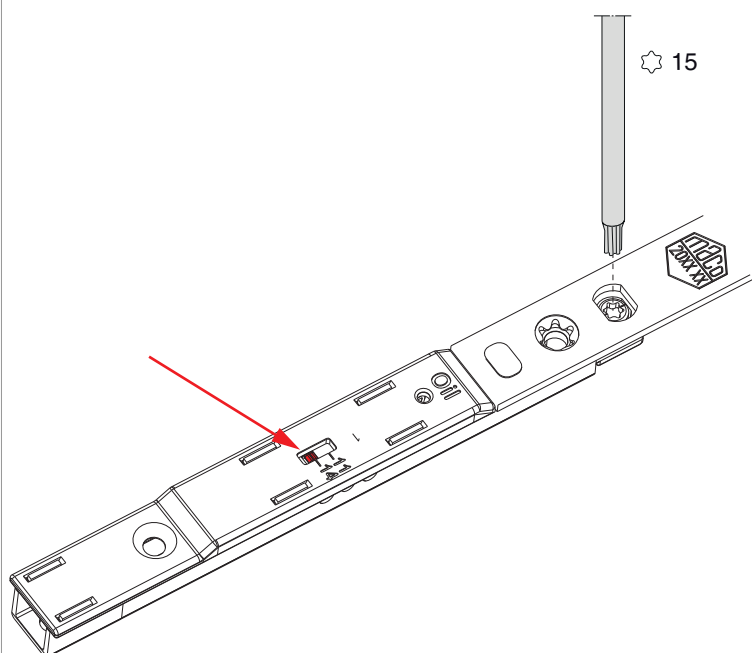

Regolazione del perno eccentrico
Uscita puntale 14 mm

Schema di tranciatura

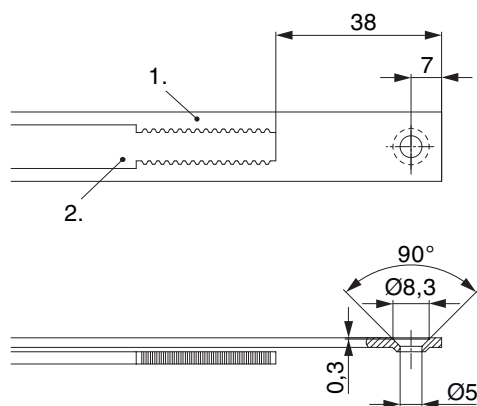

• Consigliamo di trattare il taglio dei componenti TRICOAT-PLUS con la vernice di ritocco TRICOAT-PLUS (cod. 358440).

- 1. Frontale
- 2. Asta mobile

Collegamento scarpetta dentata

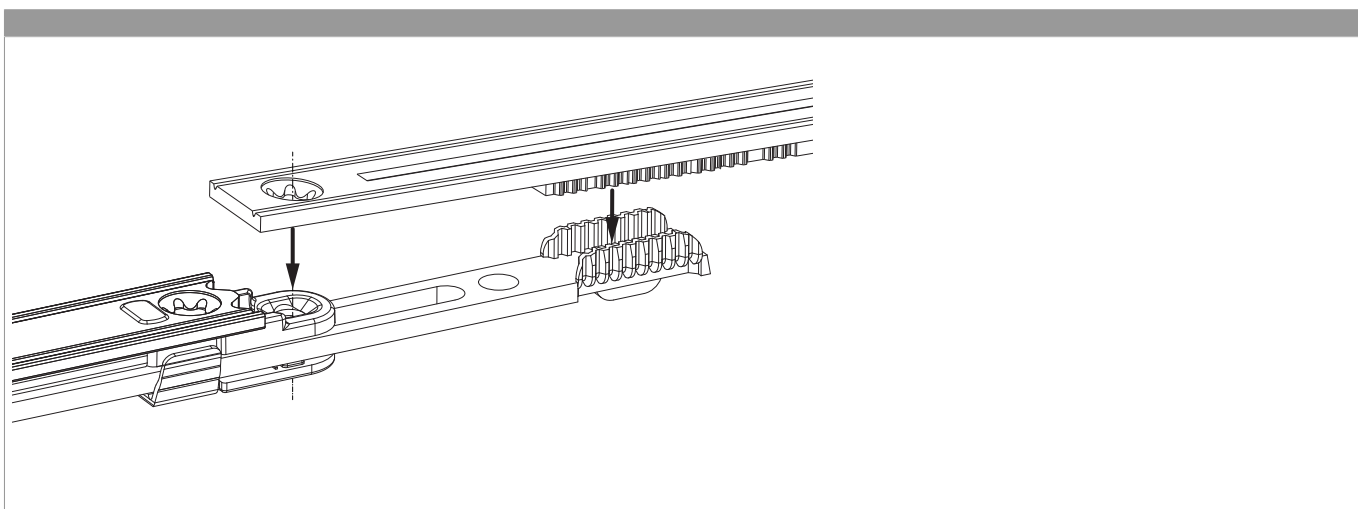

Regolazione pressione

Fungo e nottolino

