

Articolo / Item	E	C= Corsa / Stroke
2130 - 2131	vedi tabella / see table	mm 13 - 33/64"
2130/BIS - 2131/BIS	+ mm 3 / + 1/8"	mm 10 - 25/64"

Il disegno raffigura una serratura aperta / The drawing show an opened lock

Codice Code	Piani/Flat							
	A		B		E		Peso/Weight	
	mm	inch	mm	inch	mm	inch	gr	ozs
/	51		14,5		19		11,6	0,41
M7	38		0		19		8,1	0,29
N2	132		14,5		100		33,8	1,19
N9	54		14,5		22		12,3	0,43
P1	80		14,5		48		19,3	0,68
P2	57,5		14,5		25,5		13,4	0,47
P4	61		14,5		29		14,2	0,50
P7	112		14,5		80		28,1	0,99
Q7	96		14,5		64		23,7	0,84
Q8	71		14,5		39		17	0,60
Q9	67		14,5		35		15,8	0,56

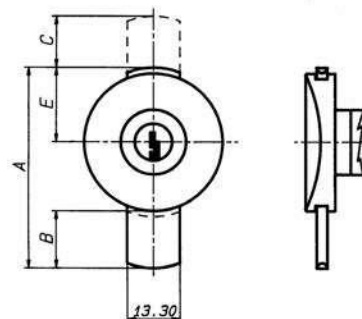

Codice Code	Piegati/Bent											
	A		B		E		P		D		Peso/Weight	
	mm	inch	mm	inch	mm	inch	mm	inch	mm	inch	gr	ozs
P9	65		14,5	0	33		9		15		17	0,60
N3	50,5		0		33		9		15		9,7	0,34
N6	47,8		0		30,3		31		11		18,3	0,65
P3	79		14,5		47		9		28		20,9	0,74

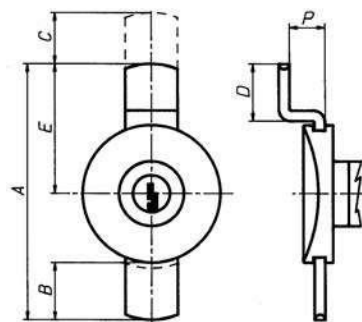

Codice Code	Piani ribassati/Shape flat							
	A		B		E		Peso/Weight	
	mm	inch	mm	inch	mm	inch	gr	ozs
R0	51		14,5		19		9,8	0,35
M2	66		14,5		34		13,8	0,49
N1	125		14,5		93		30,3	1,07
Q3	88		14,5		56		19,5	0,69
Q4	103		14,5		71		24	0,85
R1	54		14,5		22		10,5	0,37
R3	63		14,5		31		13	0,46
R8	39,8		3,3		19		6,8	0,24

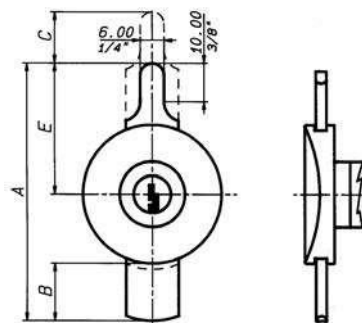

Codice Code	Piegati ribassati/Shape bent											
	A		B		E		P		D		Peso/Weight	
	mm	inch	mm	inch	mm	inch	mm	inch	mm	inch	gr	ozs
R9	65		14,5		33		9		15		15,2	0,54
M1	65		14,5		33		14		15		16,2	0,57
Q2	80		14,5		48		9		30		22,7	0,80
R4	70		14,5		38		9		15		16,2	0,57
U1	65		14,5		33		12		15		15,9	0,56
U2	70		14,5		38		9		20		16,2	0,57
U3	93		14,5		61		9		15		22,2	0,78

